



*An Online PDH Course
brought to you by
CEDengineering.com*

FHWA Bridge Maintenance: *Superstructure*

Course No: S05-006

Credit: 5 PDH

Mark Rossow, PhD, PE, Retired



Continuing Education and Development, Inc.

P: (877) 322-5800

info@cedengineering.com

This course was adapted from the “Federal Highway Administration Bridge Inspector’s Reference Manual”, Publication No “FHWA- NHI-03-045”, which is in the public domain.

XI. SUPERSTRUCTURE MAINTENANCE PROCEDURES

A. JACKING AND SUPPORTING THE SUPERSTRUCTURE

Bridge rehabilitation and repair procedures often require jacking the superstructure (See Exhibit XI.1). Since serious damage may result from an improper jacking operation, it is extremely important that this operation is correctly planned and accomplished. Improper jacking can result in collapse of the bridge, serious structural damage to the bridge, injury to workers or a traffic accident.

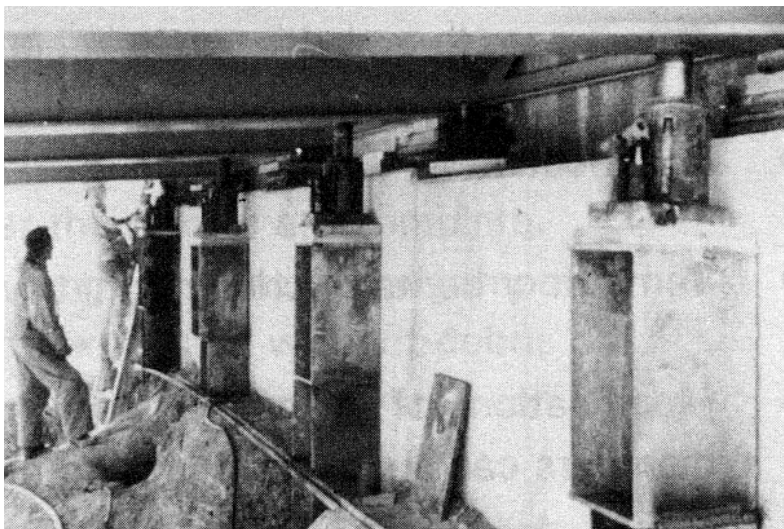

Exhibit XI.1 Superstructure Jacking

JACKING TIPS BEFORE ATTEMPTING TO LIFT THE STRUCTURE

- A heavy lifting equipment manufacturer must be contacted to determine what type of system is needed to do the lift. These manufactures can supply information on jacks, gauges, pumps, valves, etc.
- If jacking is to be accomplished by the maintenance crew, the bridge maintenance supervisor shall supply an engineer with a complete listing of the type of equipment to raise the bridge along with information on how the actual lift will progress including the lift points.
- The bridge weight and the number of lift points will determine the jack capacity. The engineer calculates the weight of the bridge and the jacking load at each lift point and provides this information to the bridge maintenance supervisor.
- Generally, all the beams in the cross section shall be lifted at the same time and height to prevent excessive stresses to the bridge.
- Establishing lift points longitudinally is also extremely important and depends on the type of the bridge. The engineer shall be consulted when establishing the lift points. For example,

simple span bridges may be lifted on one side of the span at a time. Continuous spans, on the other hand, need a jacking system to raise all the beams at all ends at the same time and height. The engineer will specify a differential beam lift tolerance to prevent excessive stresses to the continuous bridge during the operation. The differential beam lift tolerance depends on the length of the span; the shorter the span in continuous bridges, the smaller the differential beam lift tolerance. In one such project, the differential beam lift tolerance was 3 mm (1/8 in.) for a 3-span continuous steel bridge with a total length of about 60 m (200 ft).

- Typically, the jack cylinder capacity should be twice the weight at the lift point. For example, if a simple span bridge weighs 600 tons at one end, and the span has 6 lift points at that end, then the jack cylinder capacity placed at each lift point should be 200 tons.
- Factors that determine the size of the hydraulic jack (in addition to the weight of the structure) includes the clearance difference between the pier cap or abutment and the bottom of girder (or diaphragm). The crew may experience problems in attempting to lift the bridge if the sufficient room for the jack is not available.
- Placing jacks directly under the beams may lift bridge ends. Alternatively, jacks may be placed under the diaphragms. In the latter case each diaphragm may be lifted at both ends reducing the load at the lift point by half. An engineer must determine if the diaphragms have the capacity for such lifting.
- If abutments or pier caps do not provide sufficient room for supporting jacks, temporary bents may be constructed adjacent to the abutment or the cap for supporting jacks. Temporary bents may also be used at mid-span to jack the beams to take the effects of the dead load off; for example, this procedure may be needed when strengthening a steel beam by bolting a cover plate to the flange (See Exhibit XI.2 and XI.3). If a temporary bent is used to jack the structure it should be determined if the foundation is suitable for the bent.

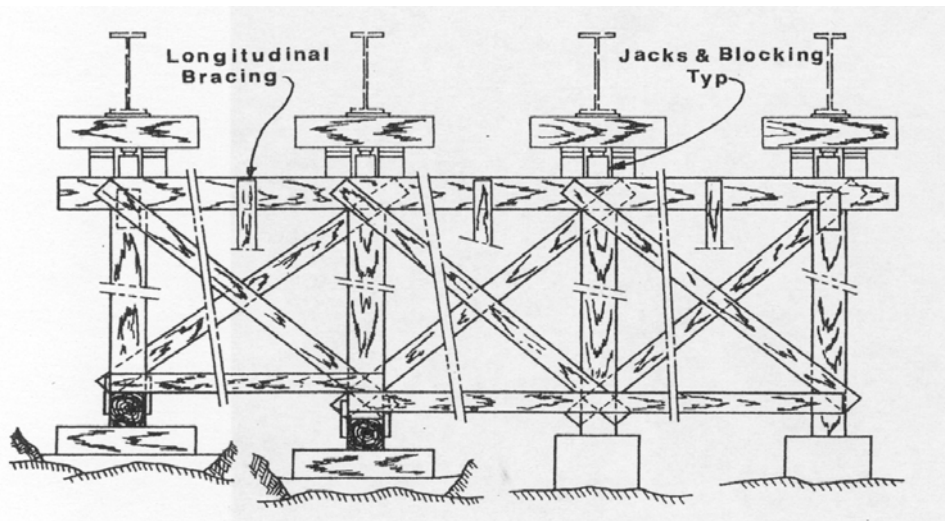

Exhibit XI.2 Transverse View of Temporary Support

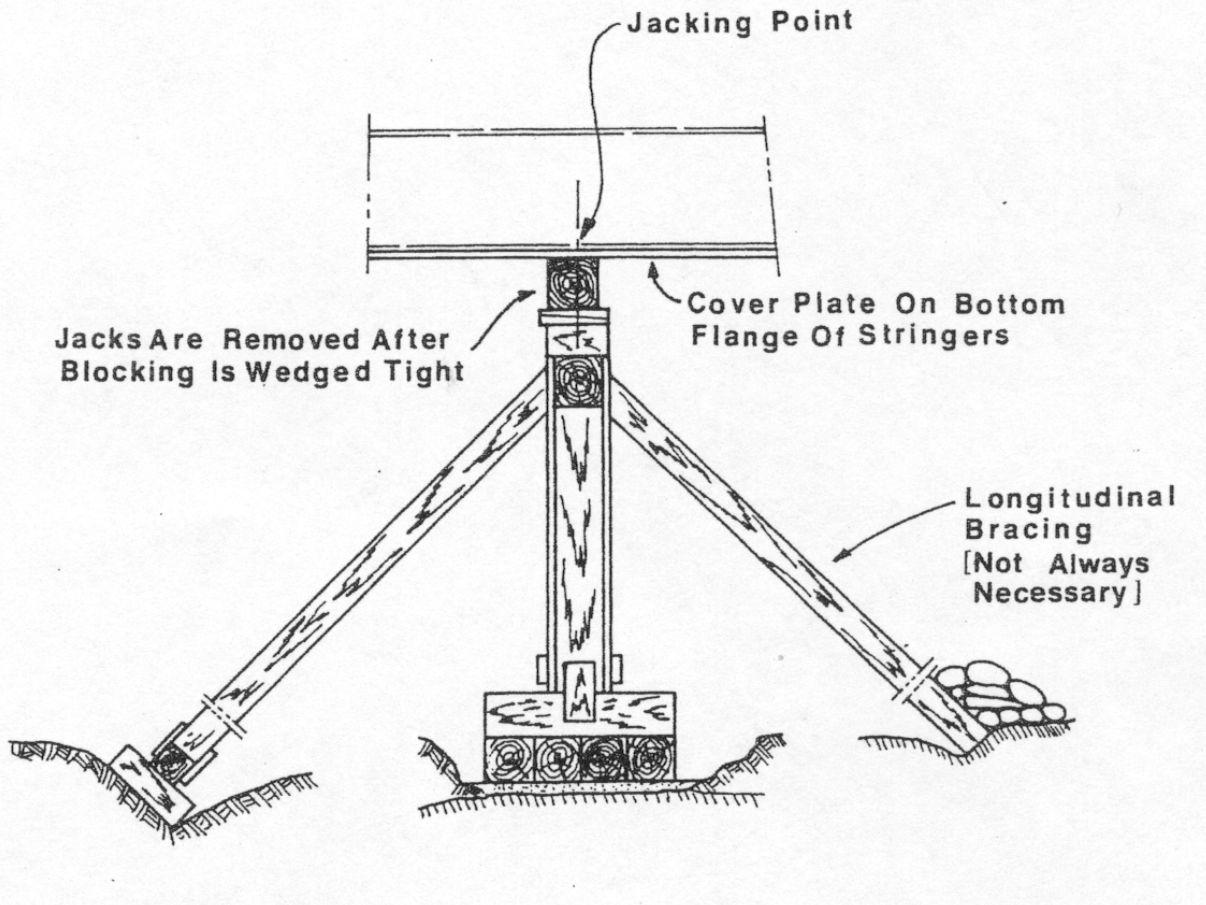

Exhibit XI.3 Elevation View of Temporary Support

- Hydraulic jacks cannot be active for long periods of time while the bridgework is in progress. Usually, the bridge is lifted and lowered onto blocking until the work is complete.
- Traffic should preferably be taken off the bridge while jacking the bridge. Once the bridge is lowered onto safe blocking, traffic can resume.
- Sometimes, traffic condition requires lifting the bridge while the traffic is on it. In that case, the engineer calculates the jacking load at each lift point considering the live load and impact from the live load. A heavy lifting equipment manufacturer should be consulted for the type of jacks with capability to hold the bridge while the weight changes as each vehicle passes over.
- Advanced hydraulic jacking systems offer synchronized lifting to help lift loads smoothly. In this process, the system senses the load to the stroke and controls the flow of the oil through the valves so that the structure is properly balanced during lifting.

JACKING THE SUPERSTRUCTURE

PRELIMINARY PLANNING

It is recommended that a structural engineer reviews all jacking plans and that the following precautions be followed:

- The jacks and the jacking supports must be straight, plumb and of adequate capacity to support the part of the bridge being lifted.
- Place jacks at locations so as not to damage the structure; jacking points on the structure should be reinforced if necessary.
- Before jacking, check deck joints for offsets that might be damaged due to difference in movement between spans. Check rails and disconnect if necessary.
- Raise and lower jacks uniformly so as to distribute the load, not over stressing or twisting any part of the bridge.
- Position blocks adjacent to the jacks and increase their height as the structure is raised so as to minimize any loss of support if a jack fails during the jacking operation.
- Do not permit traffic on the bridge while jacks support it. If traffic is permitted while blocks support the bridge, abrupt changes in elevation should be transitioned to provide a safe riding surface and avoid damage to the bridge.

STRUCTURAL CONSIDERATIONS

The jacking procedure should be designed or reviewed by a structural engineer for each setup. The following details must be considered:

- The dead load reaction that is to bear on the jacks
- Prevention of traffic on the bridge during jacking (When it is not feasible to remove traffic during the jacking operation, the live load on the jacks must also be considered)
- The size and number of jacks required
- The location of the jacks
- Temporary bents or cribbing that will be required to support the jacks
- Modifications of bridge members at the jacking locations, so that the bridge members can sustain the jacking pressure
- Space at deck joints to permit differential movement between spans
- Jack only as high as necessary

RESOURCES REQUIRED

The following materials, equipment, and personnel are necessary to accomplish jacking safely:

- Jacks of adequate size with pressure gauges
- Materials, such as beams and timbers, to provide support for the jacks, reinforce the bridge members, and distribute the pressure

- Sufficient personnel to operate the jacks concurrently

JACKING PROCEDURE

The following steps and precautions should be utilized to ensure correct accomplishment of the jacking:

- Construct the necessary bents and cribbing to support the jacks when it is not possible to locate the supports on the existing substructure. An adequate foundation to prevent differential settlement is very important.
- Reinforce bridge members as necessary to withstand the force of the jacks. Disconnect railing and utilities if necessary.
- Place jacks snugly in position.
- Restrict traffic on the span while jacks support it.
- Raise the span by jacking. Pressure gauges should be used to ensure that all the jacks are lifting the span evenly.
- Use observers placed at strategic points to look for signs of structural distress. Jack, block, and rejack until the required position is achieved.
- Protect joints and provide a transition to the span with steel plates if traffic is maintained while the span is on blocks.
- Check periodically to ensure that there is no differential settlement.
- Remove the blocks using the jacks after the repairs are complete.
- Ensure deck joints are functioning properly, the alignment is not altered, there is adequate space for expansion without debris or restriction, and the seal is watertight after the span has been lowered.

INSTALLATION OF A CARRIER BEAM

Jacking may be very difficult at some bridges due to the height of superstructure, traffic below the superstructure, or depth of water. An alternative to jacking from below is the use of a carrier beam to support the superstructure from the deck. See Exhibit XI-4 for details. It is a good idea to save a salvaged beam of appropriate size to use for this purpose. Traffic safety is a major consideration if the bridge is open to traffic while the beam is in use.

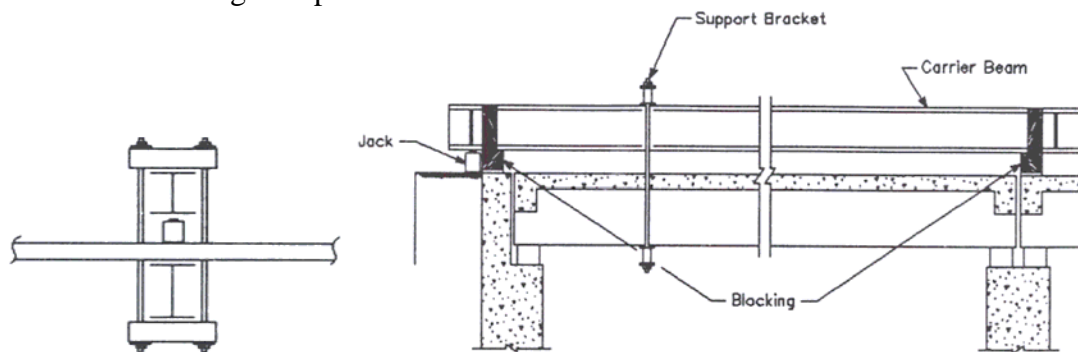

Exhibit XI.4 Carrier Beam

PRELIMINARY PLANNING

The following minimum planning is required for this procedure:

- Evaluate the options for controlling traffic during the rehabilitation. This method of support reduces the clear roadway on the deck and requires special provisions for safety since it presents a traffic hazard.
- A structural engineer should calculate the length and size of the carrier beam and tension rods required to support the dead load plus the live load when repairs are to be made while carrying traffic.
- Since the top flange of the beam is not embedded in the deck and it is free to move laterally under compression, buckling of the top flange is a possibility. A structural engineer may require bracing of the top flange based on his analysis. Diagonal bracing of the top flange against the deck, or other suitable procedures, may be used.
- A structural engineer should design and locate the support brackets so as not to damage the member to be supported.

RESOURCE REQUIREMENTS

The following major equipment and considerations will be needed to accomplish this installation:

- Suitable beam or girder
- Lifting and transporting equipment
- Jacking equipment
- Concrete drilling equipment
- Access below superstructure

INSTALLATION PROCEDURE

The procedural steps involved in accomplishing this beam installation are listed here in the order of performance:

1. Restrict traffic on the bridge deck.
2. Place the carrier beam on blocks above the area to be supported.
3. Drill holes through the deck to accommodate the rods for the support bracket taking care not to damage existing reinforcing steel. A pachometer can be used to locate the rebars.
4. Install the support bracket.
5. Place a jack under the end of the carrier beam and raise the superstructure to obtain the required clearance. Jacks may alternatively be placed on the carrier beams under the support brackets. The advantage of the latter method is that the lateral bracing of the carrier beam will not be altered during jacking.
6. Shim blocks to support the carrier beam. Perform the rehabilitation procedures.
7. Lower the superstructure onto its permanent support and remove the carrier beam after repairs are complete or concrete reaches the required strength. Repair the holes made in the deck for the support rods.

B. BEARINGS MAINTENANCE AND REPAIRS

INTRODUCTION

Bearings transmit the dead load of the superstructure and the live (e.g., traffic load) to the substructure (abutments and piers), while permitting the superstructure to undergo the necessary movement without developing overstresses. The movements are caused by temperature change, wind pressure, substructure movement, and the deflections from the loading. A bearing assembly that is frozen, out of position, damaged, or otherwise inadequate may overstress the bridge seat, beam ends, columns, or other members of the bridge and must be repaired or replaced. A frozen bearing is one that is so badly corroded or fouled that the parts will not move relative to each other as originally intended.

Bearings are of two general types: fixed bearings and expansion bearings (See Exhibits XI.5 and XI.6). The principal difference between these bearing types is that fixed bearings resist translation, lengthwise movement, but will permit rotation of the superstructure due to deflections or bending, while expansion bearings permit both rotation and translation of the superstructure. Skewed bridges and bridges that have a curved alignment horizontally need expansion bearings that will rotate and permit translation as well as transverse movement. Generally, on spans less than 40 feet, bearings need not be designed to permit end rotation. Bearings were not generally designed to resist vertical uplift, but the emphasis in the past decade on earthquake resistance has made some form of vertical restraint more common.

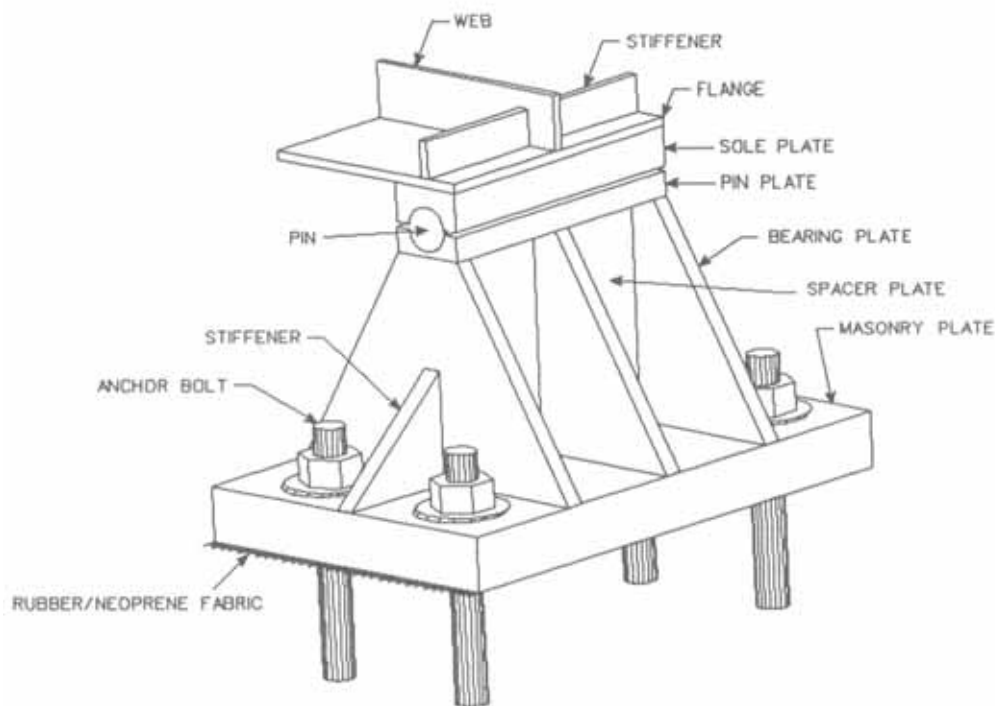

Exhibit XI.5 Fixed Bearing Device

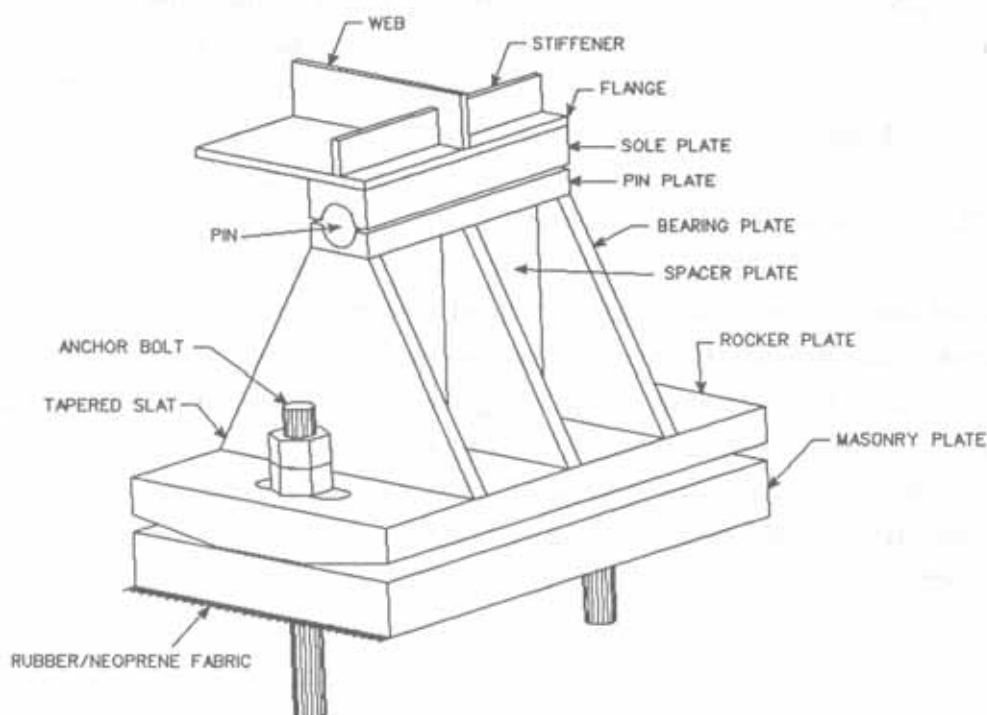

Exhibit XI.6 Expansion Bearing Device

The types of bearings that have been used in bridge building range from simple sliding surfaces to the elaborate rack and pinion arrangements. The advancement in materials development that has provided teflon and neoprene, very high strength steels, and specialty steel, such as stainless steel, has resulted in these materials being incorporated in bridge bearings in an effort to provide reliable, trouble-free operation.

Bearing problems include frozen surfaces that transmit tremendous forces to other parts of the bridge, misalignment, movement beyond capabilities, and materials failure. However, the cause of most bearing problems are open or leaking joints, substructure movement, or excessive superstructure movement. It is good inspection practice to record the position of bearings and the temperature at the time of the inspection. This can be compared at subsequent inspections to determine if the bearings are functioning. It is often possible to see signs of recent movement in the paint or rust coating.

SLIDING PLATE BEARING MAINTENANCE

Sliding plates are basically plates of similar or dissimilar metal that slide on each other (See Exhibit XI.7). Early types were steel on steel, steel on bronze, or bronze on bronze. Refinements include slightly rounding one bearing surface to reduce binding, adding a thin sheet of lead between the plates, or using a self-lubricating (oil-impregnated) bronze. Many sliding bearings utilize a polytetrafluorethylene (PTFE) pad, and a stainless steel mating surface to reduce friction.

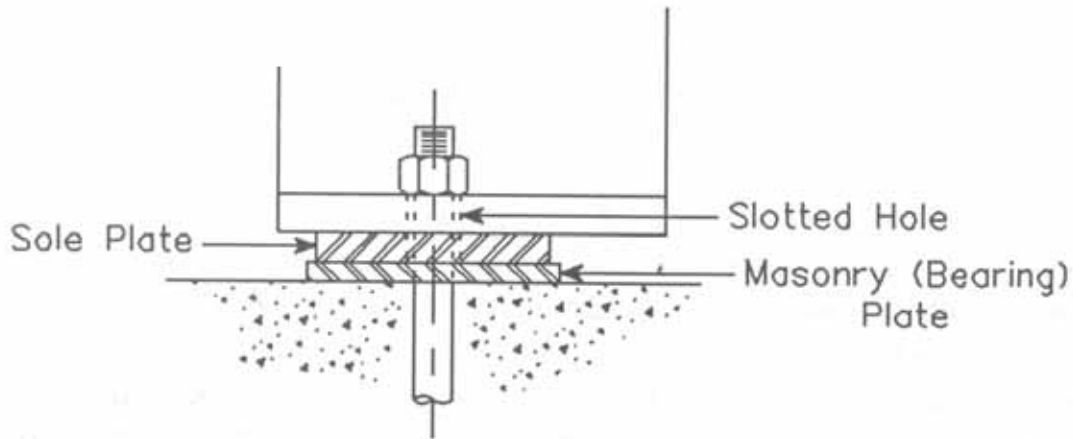

Exhibit XI.7 Sliding Plates

The most common problem with sliding plates is friction caused by corrosion. They can transmit forces to the anchor bolts sufficient to crack the concrete and cause seat failure. The only other significant problem is related to excessive movement of the sliding plate in either direction.

The only maintenance that does not require jacking is cleaning and keeping debris from accumulating around the bearing assembly unless grease fittings are provided for lubrication. If the bearing is corroded or movement is prohibited, the bridge must be jacked so that the plate surfaces can be removed, thoroughly cleaned, and lubricated with a liberal coating of good waterproof grease on both surfaces. The assembly can also be repositioned if necessary. Other methods of reducing friction between sliding plates include oil, graphite, providing lead sheets between the steel plates, or providing a bronze plate abutting a steel plate.

INSTALLATION OF GREASE FITTINGS IN SLIDING BEARINGS

In many cases sliding bearings can be equipped with grease fittings (See Exhibit XI-8).

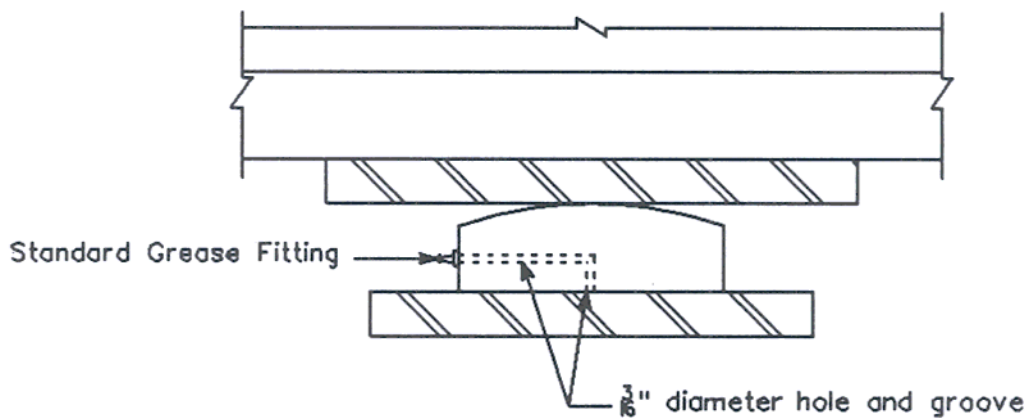

Exhibit XI.8 Grease Fittings on Sliding Bearings

Installation Procedure

The installation procedure is as follows:

1. Drill two or more horizontal holes of 5 mm (3/16 in.) diameter approximately 1/3 the distance from each end that extends half way through the sliding plate to meet the same size hole drilled from the bottom face of the plate.
2. Grind a 5-mm (3/16-in.) groove into the face of the sliding plate. Radiating grooves outward from the source of the grease (vertical holes) is optional. (It has been found that for small areas of flat bearings making full contact grooves are not necessary.)
3. Thread the horizontal holes to receive a standard grease fitting and install the fittings.

ROLLER BEARING MAINTENANCE

Rolling devices simply provide for expansion movement by using some form of roller to accommodate the relative movement of the superstructure. These devices range from a simple cylindrical roller to various forms of segmented rollers and the pinned rocker. Steel balls have been used but require special restraints to prohibit lateral movement.

Most roller bearing nests are enclosed and maintenance is difficult (See Exhibit XI-9). Some are enclosed in a sealed system with lubricants. Maintenance involves keeping the area around the bearing clean and painted. Lubrication is limited to keeper links and/or nesting mechanisms that require disassembly; if the rollers stop functioning they must be removed and refurbished. To accomplish this the end of the span must be jacked. Since the roller nests normally have to be rebuilt in a shop, it is desirable to fabricate an extra one to avoid closing the bridge for extended periods of time.

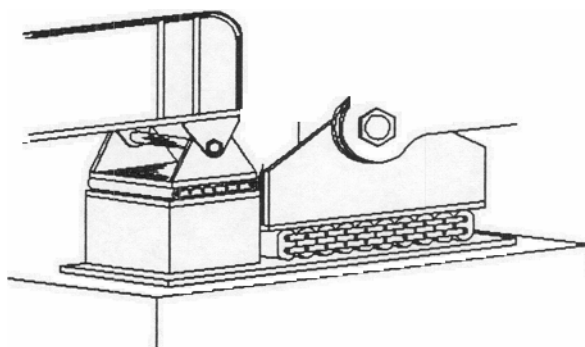

Exhibit XI.9 Roller and Rocker Nests

ROCKER BEARING MAINTENANCE

Rocker bearings are pedestals with a circular bottom that are supported by a pin. As can be seen in Exhibit XI-10, the weight of the bridge is transmitted to the rocker through the pin; it is a critical part of the assembly. It is subject to wear, corrosion, and freeze-up. The surface of the

rocker and bearing plate is affected by debris that interferes with movement. The rocker can become unstable beyond its normal range of movement.

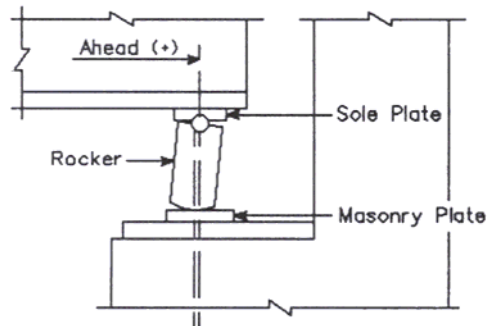

Exhibit XI.10 Rocker Bearing

Maintenance includes keeping the assembly clean, lubricated, and painted. Foreign materials under the rocker can be removed, however, if the problem is a continuous one; covers should be designed and installed to prevent this problem. If pins become worn or corroded and movement is a problem, they should be removed and replaced or cleaned and lubricated. Jacking is necessary to remove the pin.

INSTALLATION OF GREASE FITTINGS ON ROCKER BEARINGS

Special pins can be fabricated with grease fittings to provide for lubrication (See Exhibit XI-11) for details. The installation procedure is as follows:

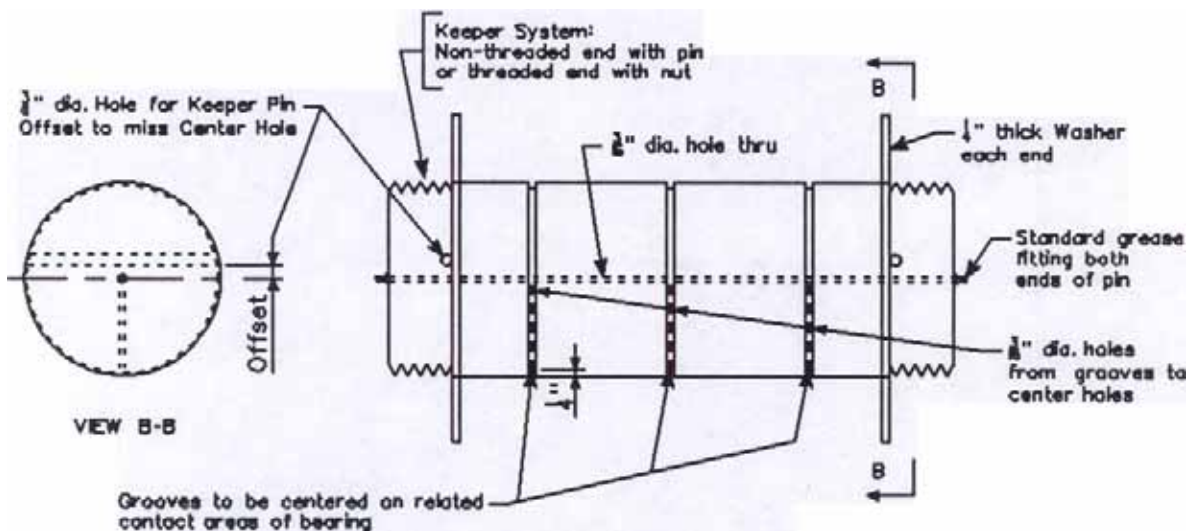

Exhibit XI.11 Pin with Grease Fitting

1. Jack bridge until pressure on pin is relieved.
2. Remove keeper pins (nut or other) and pin.
3. Drill 5-mm (3/16-in.) diameter holes in pin as shown above and grind 6-mm (1/4-in.) diameter circular grooves in pin to receive the grease.
4. Reinstall pin, keeper system and lubricate.

PIN AND HANGER BEARING MAINTENANCE

Pin and hanger bearing devices are used where the load is transmitted from the end of one span (suspended) to the other span (cantilever) and there is no substructure element directly under the bearing (See Exhibit XI.12).

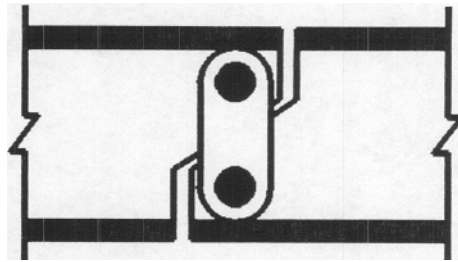

Exhibit XI.12 Typical Link Detail

While they have recently lost favor, they have been used on many existing steel beam and truss spans. Since these bearings are not located over substructure elements, they are difficult to access and maintain. Located under a joint, the pin and hanger assemblies are susceptible to corrosion. The corrosion tends to cause the assembly to freeze, preventing movement and transmitting tremendous forces to the pin and hanger, which may result in the failure of the pin or hanger. The most common failure is for the pin to break from torsional forces. If the hanger fails, the failure is normally at either end, adjacent to the hole for the pin (See Exhibit XI.13).

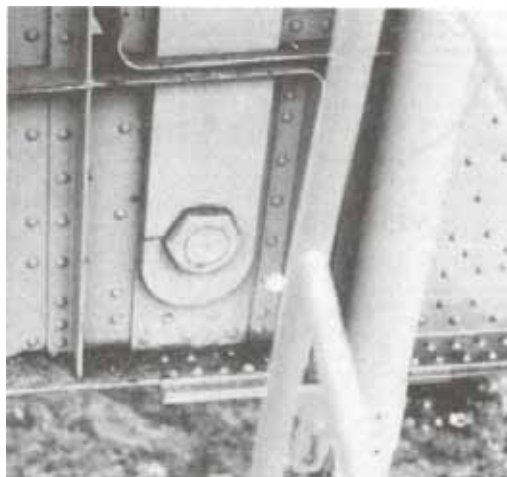

Exhibit XI.13 Cracked Hanger Plate

Pin and hanger bearings present a problem in that corrosion of the pin and its bearing surface cannot be easily detected without disassembly, and this is not feasible. Most bearings of this type are not equipped with provisions for lubrication, and freezing is often encountered. The failure of a pin and hanger bearing can be disastrous, so there is a great need to give attention to the maintenance of this type of bearing.

Redundancy has been added to pin and hangers that were nonredundant to prevent a sudden failure. Failures can occur on redundant pin and hangers if they do not receive careful inspections to identify frozen or damaged assemblies (See Exhibit XI.14).

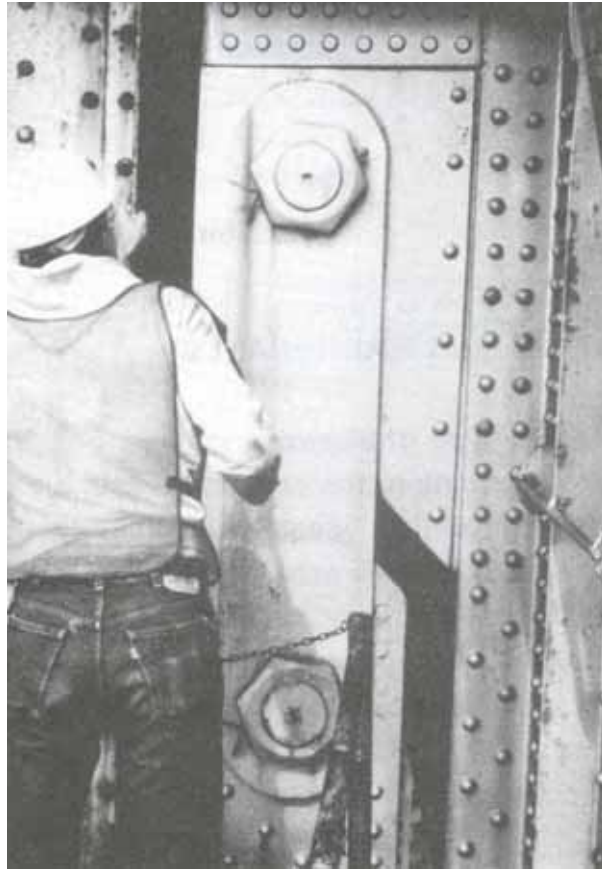

Exhibit XI.14 Pin & Hanger Inspection

Elastomeric Bearing Maintenance

Elastomeric bearings incorporate an elastic material, such as neoprene, in the form of single or multiple pads, with or without steel plates embedded into the laminations, that compress and deform to accommodate both longitudinal and rotational movements. The material has a long life and withstands repeated load cycles. These bearings can be designed to accommodate movements of up to 75 mm (3 inches) and several degrees of rotation.

Elastomeric bearings may fail due to deterioration, crushing, separation of laminations in composite pads, or excessive shear. Excessive shear is normally considered to be longitudinal

displacement on either side of the bearing greater than 25 percent of the bearing height (See Exhibit XI.15). Nonuniform compression and twisting of an elastomeric bearing are other causes of problems. Maintenance is rarely necessary unless the bearing fails or “walks out” of position due to expansion and contraction of the superstructure. To correct these problems the bridge must be jacked and the elastomeric bearing replaced or repositioned. If slippage is a continued problem an abrasive could be added to the contact surface or a keeper plate attached to the seat.

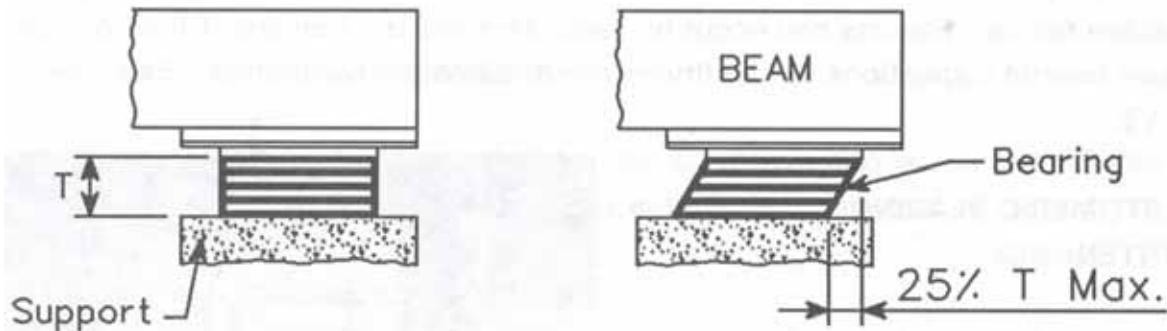

Exhibit XI.15 Elastomeric Bearing Pad

POT BEARING MAINTENANCE

A special type of elastomeric bearing, a "pot" bearing, incorporates a steel ring to confine the elastomer. The elastomer is bonded to a teflon pad and the teflon pad supports a sliding, stainless steel plate that is attached to the sole plate (See Exhibit XI.16). This assembly allows multi-directional rotations and translations. At horizontally curved structures, the translations may be guided at a certain direction depending on the location of the bearing and the configuration of the structure.

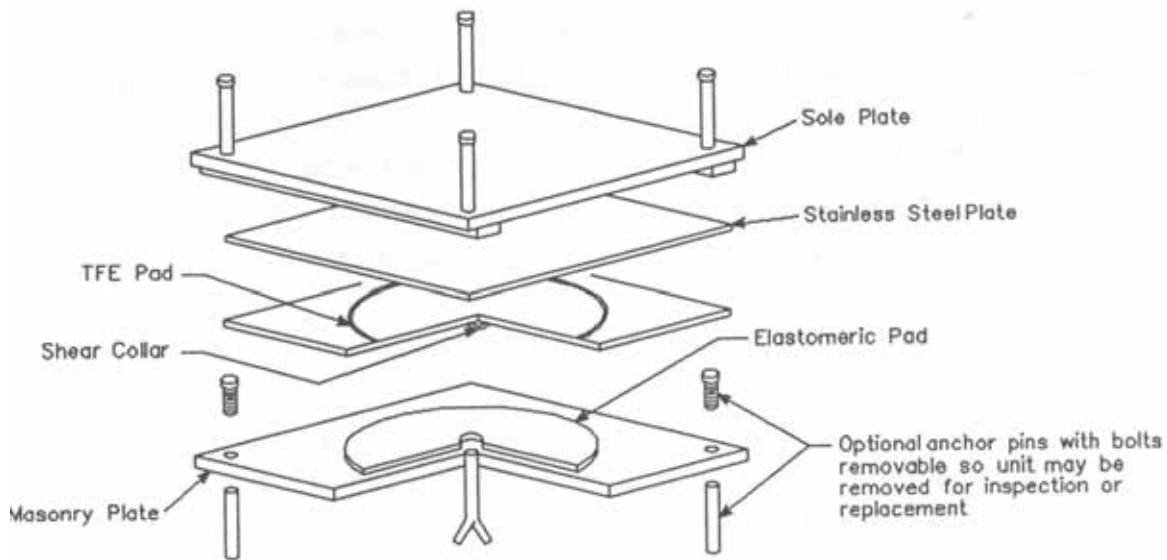

Exhibit XI.16 Pot Bearing

Elastomeric pot bearings will suffer from movement or loading that causes nonuniform compression across the bearing. A pot bearing may be impaired by a cracked pot. Elastomeric pot bearings suffer from bond failures between the teflon and elastomer, bond failures between the stainless steel and the sole plate, deterioration of the stainless steel, and cut or deteriorated teflon.

Keeping the bearing area clean and free of debris is the only maintenance that is normally required with pot bearing. When they malfunction, the structure must be jacked, and the bearing replaced or repaired.

PROPER POSITION FOR BEARINGS

When setting or resetting bearings, they should be positioned so that they are centered at the median temperature for the geographical area. For example in Minnesota it may be 7°C (45°F), in Virginia 15°C (60°F), and in Florida 24°C (75°F). The distance off center can be adjusted for other temperatures by multiplying the following formula by the degrees difference in the temperature from median: (Tributary length of span in inches) x (Coefficient of Expansion). The coefficient of expansion is 0.0000117 per degree C (0.0000065 per degree F) for steel superstructures and 0.0000108 per degree C (0.000006 per degree F) for concrete superstructures. For example when the bearing is supporting a concrete superstructure, for every 5°C (9°F) temperature difference, the bearing should be set 1.5 mm (1/16 in.) off center for a tributary span of 15 m (50 ft.). See Exhibit XI-10.

RESETTING OR REHABILITATING BEARINGS

A bearing assembly that is frozen or misaligned must be repaired or replaced; otherwise it may overstress or damage beam ends, columns or other members. Proper planning for this rehabilitation procedure must be based on a thorough analysis of the causes and conditions that make the rehabilitation necessary.

PRELIMINARY PLANNING

The following steps should be taken:

- Determine the cause of the problem. A bearing may corrode because of exposure to saltwater from the joint above, or it may be covered with debris. An out-of-position assembly may be caused by tilting or settlement of the substructure unit, approach pavement shove on the backwall, creep of the superstructure, vibration from live loads, or lateral force on the superstructure from wind, high water or an over-height vehicle. Identified cases of bearing problems and the likelihood of recurrence should be considered in the rehabilitation design.
- Evaluate the existing bearings to determine if repair, replacement or upgrading is needed. When the causes of the bearing problems are eliminated, often the existing bearings may only need to be cleaned, lubricated, or repositioned. The recurrence of frozen bearings may indicate that the design should be modified. Many new elastomeric or pot bearing devices

may be substituted for sliding and rolling metal assemblies. Replacement devices should be of proven quality and appropriate for the particular structure.

RESOURCE REQUIREMENT

The following major equipment and parts will be needed:

- Traffic control equipment
- Jacking equipment
- New bearings or parts
- Access equipment
- Cutting torch

REHABILITATION PROCEDURE

The steps in this rehabilitation are normally accomplished in the following order.

1. Construct temporary supports for the superstructure.
2. Close the bridge to traffic.
3. Use the "jacking the superstructure" procedure in the previous session to remove the load from the bearings.
4. Remove or reposition the existing bearing assembly.
5. Make seat modifications if necessary. Seat modification is especially important when the type of replacement bearing is different from the original one. For example, if a rocker bearing is replaced with an elastomeric bearing, the height of the new bearing is substantially less. As a result the seat modification will most likely include addition of a few inches of reinforced concrete pedestal anchored to the original concrete through grouted bars.
6. Position and secure the new or remodeled bearings.
7. Ensure that the bearing assembly is properly positioned for the ambient temperature.
8. Remove temporary supports.

ELEVATING BEARINGS TO INCREASE VERTICAL CLEARANCE

The previous procedure can be modified to increase vertical clearance under bridge by elevating the bearings using the following steps:

1. Jack and support the bridge slightly above its new elevation while seat and bearing modification are made. It is important to jack the spans together to avoid damaging joints.
2. Modify the seats to raise the bearings the required distance. The seat modification should be designed by a structural engineer to support the superstructure. The seat modifications may be accomplished with a steel pedestal or reinforced concrete addition.
3. Modify approaches to match the new position of the bridge deck.

C. BEAM REPAIR

INTRODUCTION

Maintenance is required on the total structure. Often the superstructure is the most difficult part of the structure to access and problems tend to be overlooked or ignored for this reason. Areas on the superstructure where maintenance is particularly important are under joints, under drains and on the fascia. Pressure washing and good protection systems in these areas will extend the life of the superstructure.

This section includes procedures for repair of concrete, steel, and timber beams. Basic procedures for maintenance, protection, and repair of concrete, steel, and timber bridge elements were covered earlier in Chapter VII. A review of Chapter VII is suggested to prepare for this section.

Often repairs to beams are associated with impact damage from over-height vehicles. Since the cost of this type of damage is often recoverable, it is particularly important to identify and correct all the damage associated with the accident. If the impact is severe, damage may be present at the bearings or in the substructure elements. For example, cracks have been found in pier columns of bridges struck by over-height loads.

REPAIR OF DAMAGED REINFORCED CONCRETE BEAMS

It is important to keep the concrete superstructure elements clean and protected, particularly in areas where the concrete is exposed to salt water from the deck or below. Concrete sealers or coatings have proven effective to protect areas exposed to salt water. Since they must be applied to a clean surface to be effective, it is recommended that they be applied before the surface is contaminated. Otherwise, the surface must be blast-cleaned before application.

An engineer should evaluate damage to concrete beams and determine the type of repair needed and if the work should be performed in-house or by contract. Maintenance crews often perform minor repairs on concrete beams. These repairs include impact damage from over-height vehicle and spalling from corrosion of the reinforcement. Many factors influence the best method of repair. Two primary factors to consider are the location and severity of the damage. For example, a small damaged area is not structurally significant in tension areas if the reinforcement is not damaged. The major concern is protecting the reinforcement from corrosion due to exposure. Therefore, the repair might be a hand-applied surface patch or, if appearance is not important, painting the exposed rebar may be adequate. Shotcrete may also be used for surface repairs if the cost is not prohibitive.

A formed repair using a concrete material with appropriate additives to control set time, shrinkage, and permeability is often the most permanent type of repair and the appearance is likely to be the most satisfactory. The size and location of the repair is a consideration in selecting the best method of placing concrete in formed repairs. It is difficult to get good consolidation of normal slump concrete in the small confined spaces, particularly if the new

concrete must bond to existing concrete above the repair. For this type repair, preplacing the aggregate and pressure injecting the grout or dry-pack placement should be used. See Exhibit XI.17.

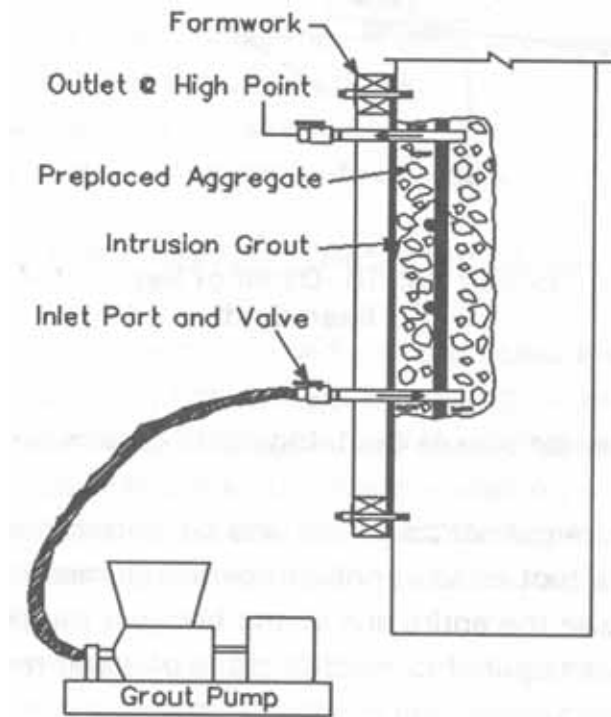

Exhibit XI.17 Preplaced Aggregate

Structural repairs may include supporting the superstructure while the repair is in progress. This can be accomplished with temporary bents or carrier beams, which must be designed by an engineer. It may be necessary to jack the dead load stresses out of the damaged area before the repair is made if the damage extends into a compression area or if the reinforcement is damaged.

REPAIR OF DAMAGED CONCRETE BEAM ENDS

Following are step-by-step procedures for repairing damaged concrete beam ends (See Exhibit XI 11.18).

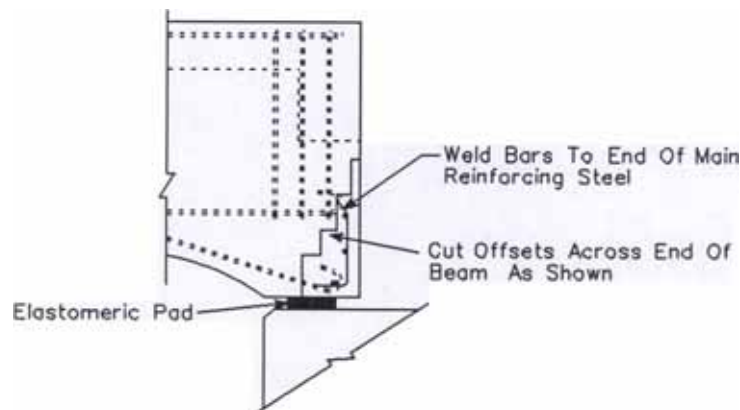

Exhibit XI.18 Detail of Repaired Beam End

1. Direct traffic to the far side of the bridge until repairs on the beam end are complete.
2. If the superstructure cannot be jacked and supported from existing substructure, construct temporary bent for this purpose.
3. Place jacks and raise the entire end of the bridge a small fraction of an inch. The lift should be only that required to take the load off and to insert a piece of sheet metal as a bond breaker for the new concrete.
4. If beam has an insert plate welded to the sole plate, remove sole plate anchor bolt nuts and washers.
5. Place the sheet metal bond breaker, referred to in step 3, on the beam seat.
6. After sawcutting concrete to avoid feathered edges, remove damaged concrete in steps as shown in Exhibit XI.18, to provide a horizontal bearing surfaces.
7. Place new reinforcement as needed, making sure it is properly lapped, anchored, or mechanically attached to the existing steel.
8. After forming, clean the surface of the existing concrete and apply bonding material. Bonding agent may be an epoxy coating.
9. Place new concrete using a non-shrink additive. The bonding material shall not set and dry before placing the new concrete.
10. After the concrete has reached sufficient strength and the repaired area has been visually inspected and sounded, lower all beams simultaneously and uniformly and place them on the bearings.
11. Place and tighten anchor bolt washers and nuts if applicable.
12. Remove the jacking system.

STRENGTHENING CONCRETE BEAMS WITH FRP STRIPS FOR FLEXURE

Fiber reinforced polymers (FRP) strips, due to their high tensile strength, can be bonded to concrete externally to increase the flexural capacity of concrete beams and slabs. The strips typically arrive on site packed as a coil in a box. The tensile strength of FRP can be several times the tensile strength of steel depending on the type of fiber. For example, the tensile strength of FRP with glass fibers is about 1,520Mpa (220 ksi) and that of FRP with carbon fibers is 2,400 MPa (350 ksi). Regardless of their higher cost, usually, FRP with carbon fibers are preferred for strengthening concrete elements. FRPs are also much lighter than steel. Their unit weight is even less than the unit weight of concrete.

CONCEPT

The concept of increasing concrete's flexural capacity with externally bonded FRP strips is similar to that of conventionally reinforced concrete. When oriented parallel to the reinforcement and bonded to the concrete, the FRP strip supplements the tensile strength of the reinforcing steel. The strips are typically bonded to the bottom of the beam or slab in the zones of positive moments and sufficiently developed.

The component to be strengthened shall be analyzed by a structural engineer prior to installation. The structural engineer determines the width, thickness, length, location and the number of the strips to be installed. As part of the analysis, the structural engineer determines the maximum

allowable amount of the FRP for the installation so that the mode of failure under overload will be tension rather than compression. Compression failure of concrete is a sudden failure and not desirable.

INSTALLATION

FRP strips can be installed on concrete using the following general steps (manufacturer should be contacted for detailed procedures):

1. The concrete substrate is thoroughly inspected, unsound concrete removed and repaired. Cracks must be injected with a resin and all surface defects filled using resin. The surface must be clean and dry.
2. The strip should be cut to the size using heavy-duty shears. Gloves, masks and goggles are recommended when handling FRPs.
3. The concrete surface is then primed with an epoxy resin using a spatula. The width of the primed area is approximately 13 mm (1/2 in.) wider than the strip.
4. Next, the face of the FRP strip to be bonded to the concrete is coated with the same epoxy resin used as a prime on the concrete.
5. After the concrete and the strip have been prepared, the strip is placed on the concrete (epoxy to epoxy). The strip is then seated with a rubber roller and pressure and not disturbed for 24 hours after the application.

STRENGTHENING CONCRETE BEAM WITH REINFORCING STEEL FOR SHEAR

The Kansas DOT has developed a repair system for reinforcement of concrete beams to increase shear capacity. Two bridges that suffered diagonal shear cracks near the ends of the girder were repaired using the following steps:

1. Locate and seal all the girder cracks with silicon rubber.
2. Mark the girder centerline on the deck.
3. Locate the transverse deck reinforcement.
4. Vacuum drill a series of 45° holes from deck through beam that avoid the reinforcement. The direction of drilling is perpendicular to the shear cracks.
5. Pump the holes and cracks full of epoxy.
6. Insert reinforcing bars into the epoxy-filled holes.
7. After epoxy has cured, remove silicon rubber.

REPAIR OF DAMAGED PRESTRESSED CONCRETE BEAMS

Prestressed concrete should be maintained and protected the same as reinforced concrete. However, the consequences of poor maintenance can be more serious. The strands in prestressed concrete members have been pretensioned, thereby squeezing the concrete and placing it in compression. The tendons place sufficient compression in the concrete to prevent any part of the section from going into tension when the bridge is loaded.

Prestressed members have thinner sections than conventionally reinforced concrete. Deterioration is more of a concern. Cracks in prestressed concrete and corrosion of the strands are also a concern. Since the tension is high in the tendons, and the concrete is squeezed together, the loss of a significant amount of concrete can cause the remainder of the section to crush and fail. A tendon break, due to an impact or corrosion, causes a minor effect. Several tendons snapping may cause a sudden failure of the bridge.

Special procedures are needed when repairing prestressed concrete to restore this dynamic state of stress. If a significant amount of concrete is replaced, the compression must be removed from the concrete in the beam around the damaged area. This is done by placing a calibrated load on the bridge while the new concrete is placed and is reaching its design strength.

Tension must be placed back into broken tendons as part of the repair. Florida DOT uses tendon splices, which are available to accomplish this (See Exhibit XI.19). They are anchored to the ends of the damaged tendon and a threaded coupler nut between the two anchors is torqued a prescribed amount to produce the tension needed in the tendon.

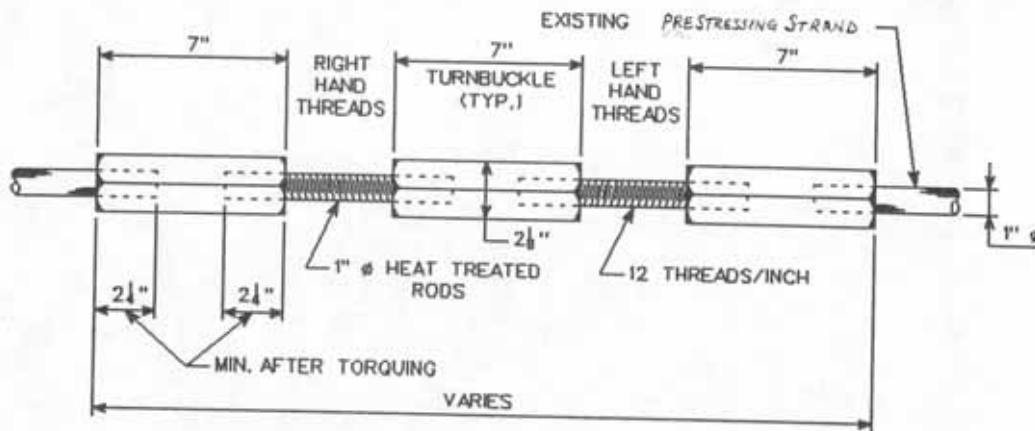

Exhibit XI.19 Tendon Splice Details

A different method attaches post-tensioning strands in ducts outside the beam to repair damaged tendons. The ducts span the damaged area. They are located above the flange and anchored to the existing concrete as shown in Exhibit XI.20. Measures should be taken to prevent corrosion of external post-tensioning strands and anchor devices.

REPAIR PROCEDURE FOR EXTERNAL POST-TENSIONING

This method includes the following steps:

- Drill holes through the web (See Exhibit XI.20) for grouting reinforcing steel to tie the old and the new concrete. Care must be exercised to avoid drilling through the tendons or reinforcing steel.
- Roughen and clean the surface of concrete where the new concrete is to be bonded.
- Install the post-tensioning ducts, grout the reinforcing steel, and install the forming for the new concrete.

- Coat the contact surfaces with epoxy resin and place the new concrete while the epoxy is still tacky.
- After the concrete has attained the design strength, tension the strands to the specified load. Strands should be tensioned in a sequence to balance the load on each side of the flange.
- Fill the post-tensioning ducts with grout.

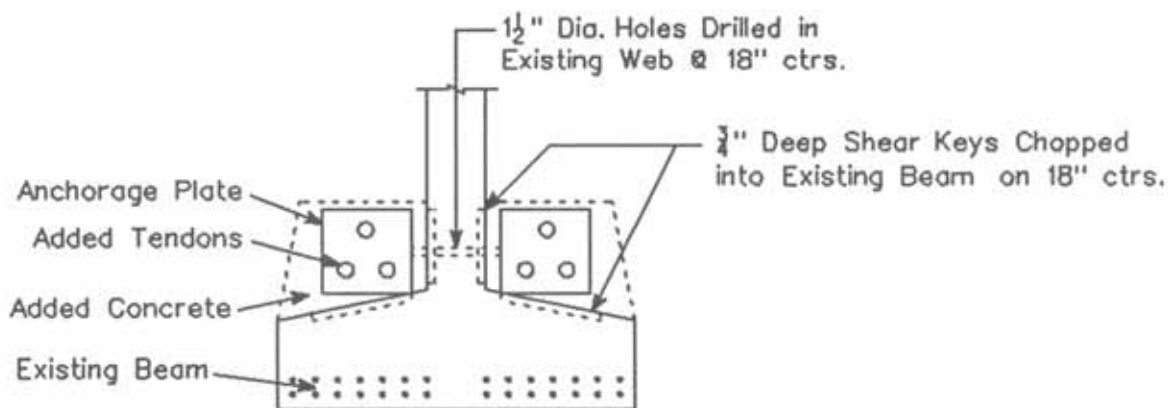

Exhibit XI.20 External Post-tensioning of Prestressed Girder

REPAIR OF STEEL BEAMS, GENERAL

There are three basic types of damage that occur to steel beams: corrosion damage, impact damage, and fatigue damage. Good maintenance can prevent corrosion damage. However, if it is permitted to take place, the damage can be as severe as impact or fatigue damage. FHWA sponsors a training course, entitled *Economical and Fatigue Resistant Steel Bridge Details*. It contains very good information on how to retrofit existing bridges to make them fatigue resistant. These details should also be useful in performing other repairs to steel beams in order to avoid future fatigue problems.

Often repairs to steel beams involve adding material, such as plates or angles, to compensate for the damage. Because of the difficulties of achieving good quality field welds, it is recommended that the sections added be bolted rather than welded. Welded repairs are sometimes made at locations on the beam where fatigue is not likely to be a problem or where rigid quality control is exercised.

REPAIR OF CORROSION DAMAGED STEEL BEAM END

Following are step-by-step instructions for repairing a corrosion-damaged beam end:

1. Relieve the load at the bearing by jacking under the sound portion of the beams.
2. Cut out the corroded area, rounding the corners to a minimum radius of 75 mm (3 in.) to avoid abrupt changes (re-entrant corners) (See Exhibit XI.21). Bearing stiffeners, if present, must be removed.
3. Weld the new section into place using full penetration welds. The new section may be either a suitable rolled beam section or shop fabricated from other suitable shapes. Replace the bearing stiffeners where required.

4. Lower the span to bear. Check for distress.
5. Remove jacking equipment and other temporary supports.

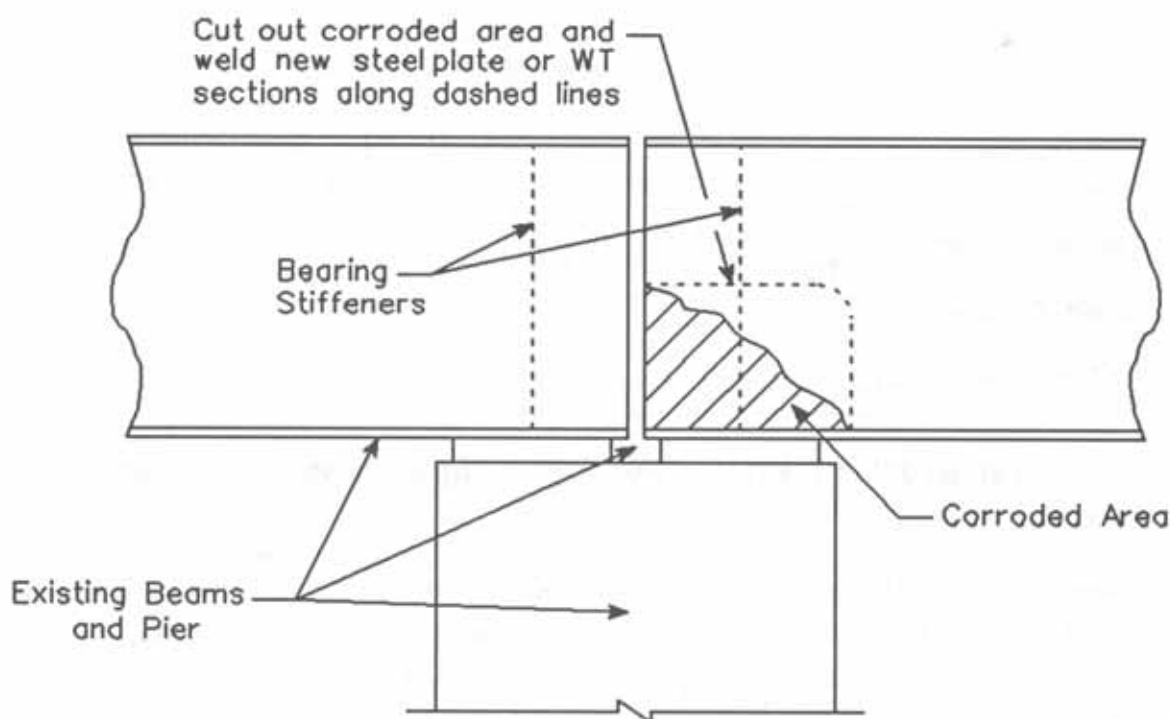

Exhibit XI.21 Corroded Beam End Rehabilitation

REPAIR OF IMPACTED STEEL BEAM

Impacted steel beams are often bent and gouged in the flange at the location of the impact. The following procedure may be used to repair impacted steel beams (See Exhibit XI.22).

1. Remove the paint within 152 mm (6 in.) around the damaged flange and web.
2. Heat-straighten beam flange and web at the location of impact. See the next topic for the procedure for heat straightening.
3. Drill a 25-mm (1-in.) retrofit hole at the tip of the gouge to terminate the progression of the crack.
4. Prepare the existing beam web and bottom flange for bolting of two angles and two plates (one on each side). Drill the flange and web and ream holes to 24 mm (15/16 in.) diameter for 22 mm (7/8 in.) high strength bolts. It should be noted that the grade and size of the angles or plates and the type, number, and location of the bolts shall be designed by a structural engineer.
5. Place the new bolts and connect the angles and the plates to the beam.
6. After the repair, paint the beam where the paint is removed.

It is important to note that on non-composite structures, to increase the efficiency of the repair, the beams may be jacked at the mid-span to remove the dead load effect prior to fastening the angles and plates. On composite structures, however, jacking the beams at the mid-span may

result in cracking of the concrete deck. Thus, the concrete deck shall closely be monitored for cracking while jacking, and jacking should immediately be terminated if cracking is initiated.

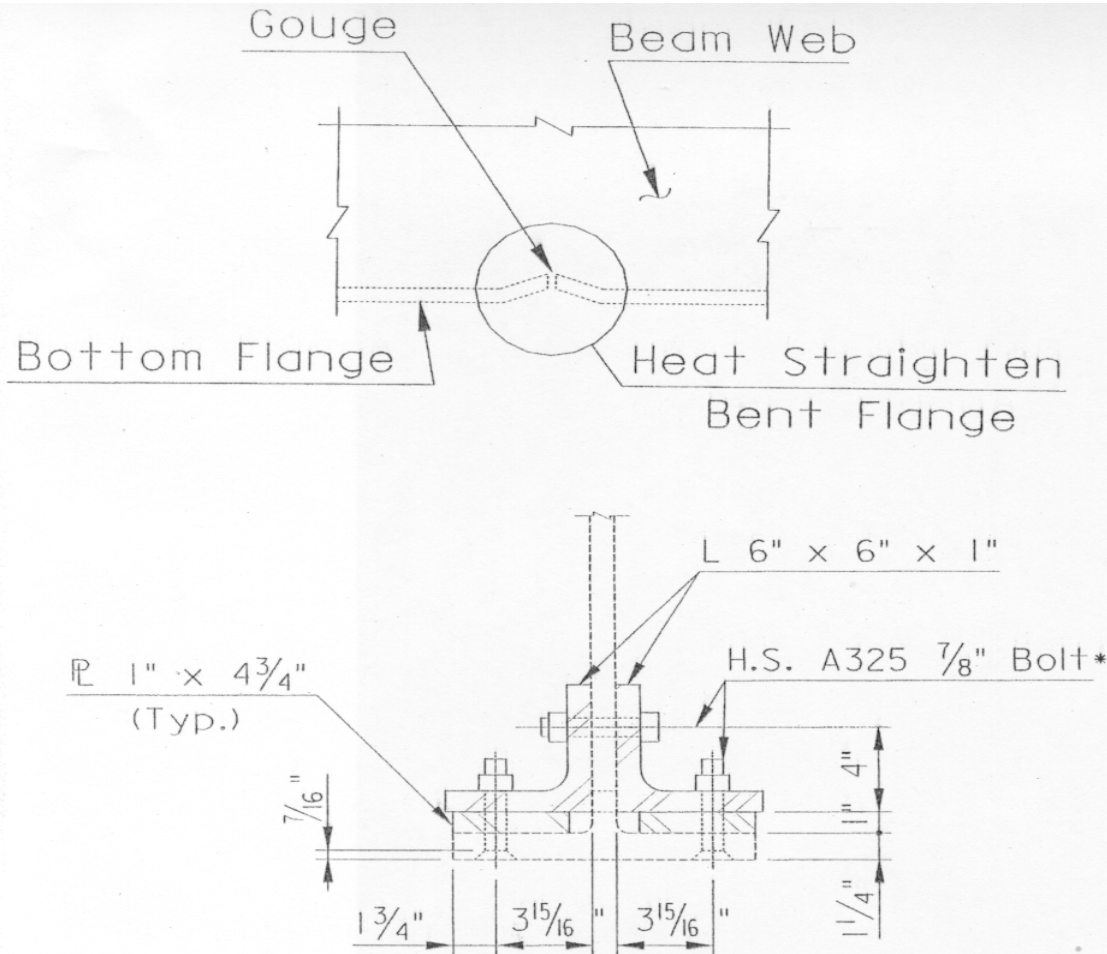
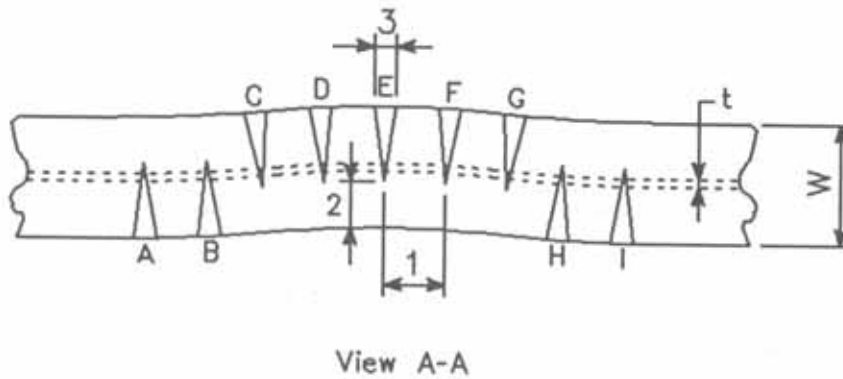
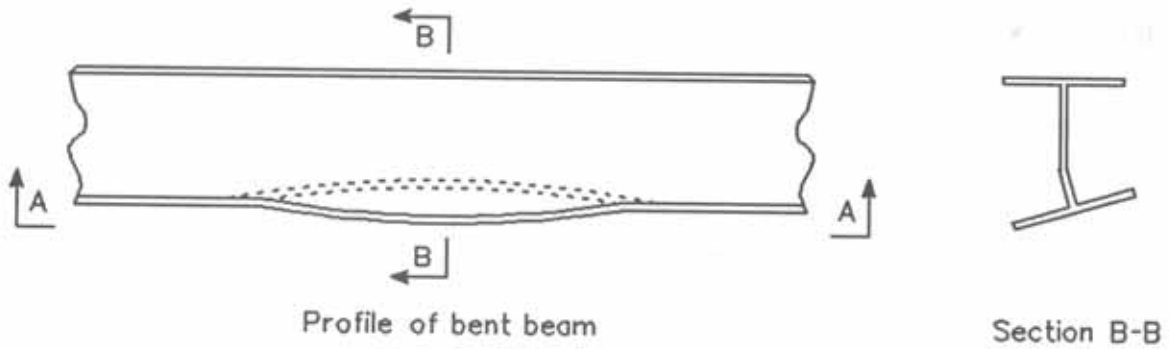

Exhibit XI.22 Repair of Impacted and Gouged Beam Flange

HEAT STRAIGHTENING A DAMAGED STEEL BEAM

A common problem for bridge owners is impact damage to steel beams due to over-height loads. Heat straightening is used by many agencies to repair the damage. In the procedure heat is applied to the damaged steel beam, causing the steel to deform in a predictable direction upon cooling. Using an oxyacetylene torch, the heat is applied to the surface of the steel using torches in a series of "V" patterns. The heating starts at the apex of the V-shaped area. See Exhibit XI.23.



Dimensions	Size	General Pattern Sequence
1	Varies as necessary - $2/3 W$ to W generally	E D F B H or
2	$W/4$ to $W/2$	E C G B H D F A I
3	About 6", or $W/3$ to $W/2$	Note: Other sequence options may be used also.

Exhibit XI.23 Locations, Size, and Sequence of Heats for Flame Straightening

As the steel cools it will shrink and move toward the wide end of the "V." If a load is applied from a "come-along" or jacking device, the efficiency of the heat straightening is improved.

The objective of this procedure is to restore the steel beam to its original shape and position while minimizing the damage to the material. It should be planned and monitored by an engineer familiar with the procedure. The following precautions must be followed:

- The damaged area is inspected very carefully before, during, and after the repair to identify flaws, tears, or cracks.

- The heat and force is applied so to accomplish the move gradually, rather than abruptly, to avoid tears in the steel as a result of the procedure.
- The heat is controlled so that the steel is not heated above 650°C (1200°F) to avoid damaging the properties of the material. Heat sticks are used to indicate when the steel reaches the maximum temperature.

When a steel member is bent it is stretched beyond its yield point. Therefore, the properties of the material are changed even if it does not crack or tear. When a steel beam is straightened, the ductility of the steel is reduced. Even if the shape is restored perfectly, it is possible that the capacity and service life of the member has been reduced. If the capacity of the beam is in question after the repair, it is common practice to strengthen the flange with a bolted cover plate or angles. However, strengthening may not be necessary if the damage is to the fascia beam, which is often over designed because of its location in relation to the traffic on the bridge. Because of the uncertainties associated with heat straightening, it is recommended that beams receiving this procedure be checked closely during subsequent inspections for cracks associated with the damage. Ultrasonic testing or dye-penetrant test may be used.

REPAIR OF TIMBER BEAMS

Any crack in a timber bridge beam (stringer) causes a loss of load-carrying capacity and may require immediate repair or replacement before traffic can use the bridge. Timber beams with a longitudinal crack can be repaired by stitching or by clamping it together with steel plates top and bottom, held together by bolts that extend the height of the beam. See Exhibit VII.37.

Normally replacement is the most cost effective repair for decayed or damaged timber beams. A temporary repair can be made in some cases by turning stringers with small damaged areas, such as around the planking spikes. Often the repair will take as much time and effort as putting in a new stringer and will result in a weakened beam with a short service life.

It is easier to replace a damaged beam if the deck is removed but if the deck is heavily spiked to all the beams, and only one beam is damaged, this may not be practical. The usual practice is to install a new beam alongside the old beam, or one on each side. The new beam can be installed by cutting off one end of the beam at an angle so that it can be inserted into the space between the cap and the deck while clearing the opposite cap. After positioning of the caps the beam should be jacked up tightly against the deck, and hardwood or metal shims installed between the beams and the cap. The cut-off wedges from the angle cuts can be used as shims. The deck then should be spiked to the new beam (See Exhibit XI.24).

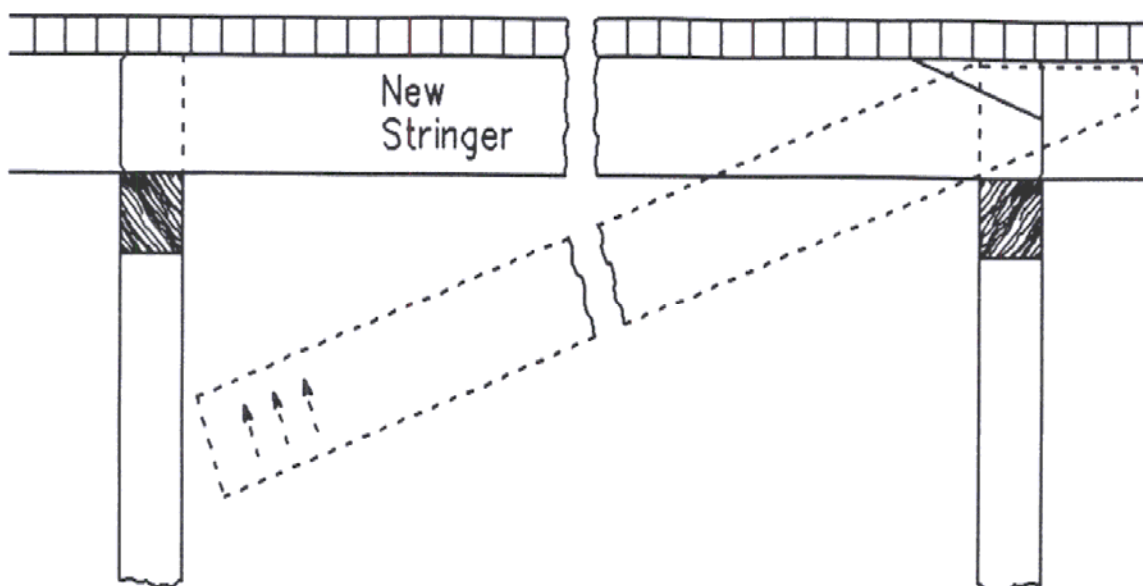

Exhibit XI.24 Timber Stringer Replacement

D. TRUSS REPAIR

INTRODUCTION

Truss bridges are usually made of steel, although old trusses of wrought iron are still in existence. Repair normally consists of replacing a damaged member or strengthening weakened members by adding steel plates. Welding should be avoided if possible in repairing older trusses since the steel has a high carbon content. A structural engineer should be consulted to make this assessment and to develop the repair procedures. The method of support during the repair is much different depending on whether the member is in tension or compression.

MAINTENANCE AND REPAIR OF STEEL TRUSSES

All steel trusses are susceptible to damage by rust and corrosion. As a general rule, main load-carrying members cannot withstand a substantial loss of section before becoming overstressed. Through trusses and pony trusses are generally narrow and particularly susceptible to collision damage because the truss members are close to the roadway. The portal and sway bracing of through trusses is readily subject to collision damage from over-height loads. The condition of the pins is critical to a truss with pin-connect eye-bars. Because all loads pass through the pin, its failure can result in loss of the span.

A good cleaning and spot painting program is mandatory to prevent rust and corrosion damage of all types of truss bridges. The cleaning procedure is vital for the pins in pin-connected structures to ensure that the joints are free to function. Cleaning and painting are effective in preventing loss of cross section due to corrosion.

Common repair procedures used to correct truss deficiencies include:

- Members damaged by rust or corrosion, to the extent that they are overstressed, are repaired by adding strengthening plates to compensate for the affected area.
- Temporary repairs may be made to impact-damaged truss members by using struts to reinforce damaged compression members and cables with turnbuckles to accept part of the load on damaged tension members. Fractured members usually require partial or total replacement.
- A fractured eye-bar of a pin-connected truss can also be repaired temporarily with a cable to accept part of the stress, but permanent repair will require replacement of the member.

One method that can be used to reduce collision damage to a truss is replacement of the railing with of a modern railing system on the bridge. Structures with low overhead lateral bracing may require replacement and raising of the bracing to provide work clearance.

REPAIR OF TENSION MEMBERS

Corrosion, overload, and impacts from oversized vehicles damage diagonal tension members. Following is a suggested repair procedure for a diagonal tension member (See Exhibit XI.25):

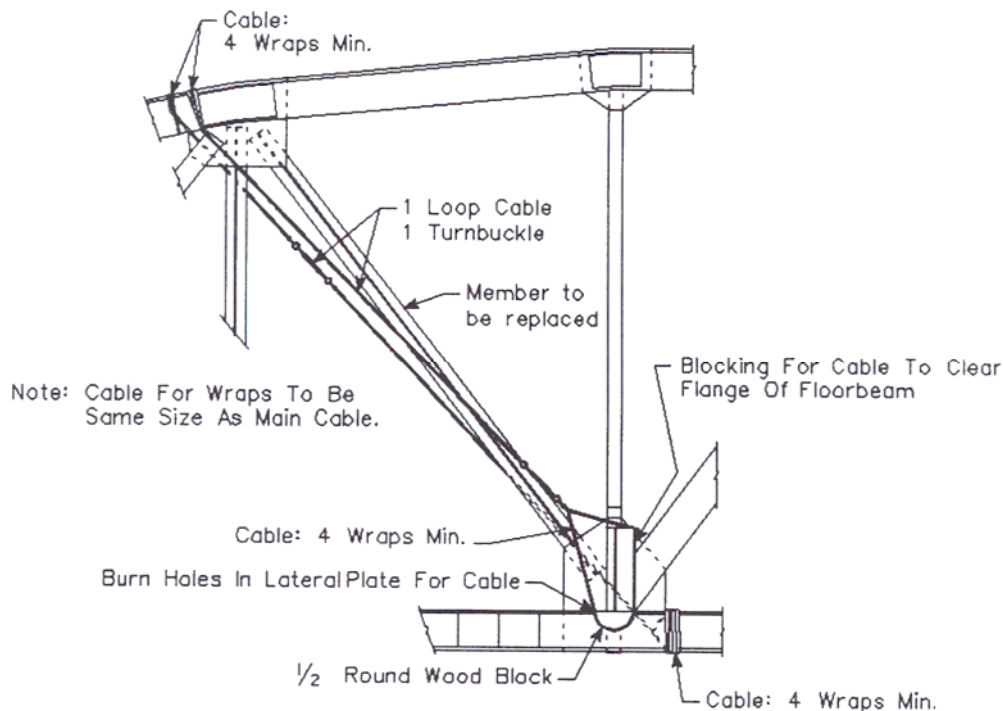

Exhibit XI.25 Truss Diagonal Replacement for Riveted or Bolted Connections

1. Design and acquire a replacement member that meets the capacity requirements including the additional load of the repair activity.
2. If the bridge is open, traffic should be restricted to one lane on the opposite side.
3. Cut and install wood blocking for cable clearance as required.

4. Install a cable having the capacity to carry the full dead load in the diagonal plus the live load distributed from the restricted traffic.
5. Tighten the cable system.
6. Remove and replace the damaged member. If the old and new member consists of more than one section, the sections should be removed and replaced individually, using high-strength bolts and keeping the load as symmetrical as possible.
7. Install batten plates or lacing bars as required along the member and tighten all high-strength bolts in the new member.
8. Remove the cable support and other temporary components and restore the bridge to normal traffic conditions.

A vertical tension member can be repaired using the same type cable support and the same procedure.

Damaged diagonal tension members consisting of two eye-bars can be replaced by using rods as shown in Exhibit XI.26, with U-bolt end connections. With no traffic on the structure, one of the eye-bars can usually be replaced at a time.

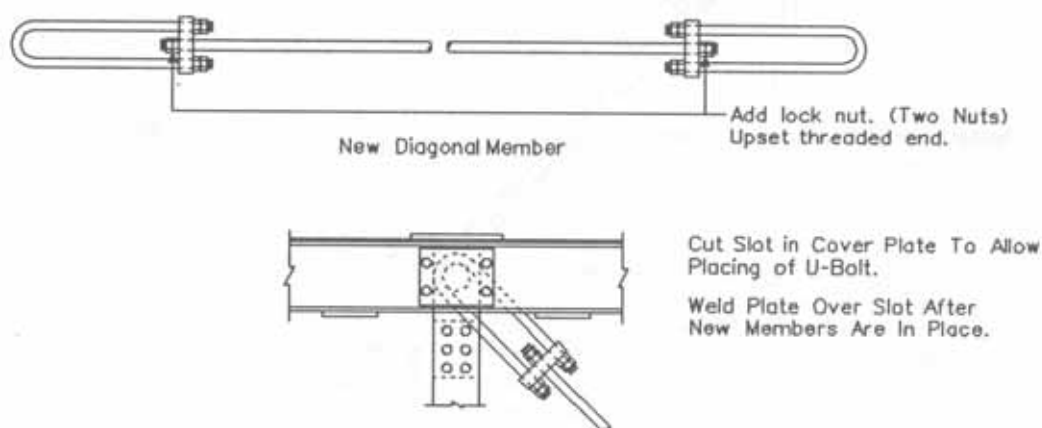

Exhibit XI.26 Truss Diagonal Replacement for Pinned End Connections

REPLACEMENT OF COMPRESSION MEMBERS

The difference between replacing a compression member and replacing a tension member is that a heavier and more expensive temporary support system is needed for a compression member.

- The temporary support system must be capable of supporting the compression load while the member is removed and replaced. Therefore, each member that makes up the temporary support system will consist of a larger, "column-like," section.
- To provide room for removing the old compression member, the temporary support must be framed around the old member. It is not mandatory that the temporary support be more than one column. However, since the temporary support is offset, it must be able to resist the unbalanced load that is created when the old member is removed.

- As the temporary support is installed, jacking relieves the load on the damaged member. The temporary support is designed to support the jack(s).

REPAIR OF DAMAGED TRUSS MEMBERS

If the damage is localized, such as a transverse crack in one of two channels that make up the bottom chord of a truss, a splice can be designed by a qualified engineer to solve the problem. Exhibit XI.27 shows an example of this type repair. The repair procedure is as follows:

1. Bolt a side splice plate to the damaged member as shown in Exhibit XI.27. Remove any rivet heads that would interfere with the splice plate if the repair were near a connection and replace with high strength bolts. The plate should be centered over the damage and sized by an engineer.
2. If necessary, remove old tie plates (or lacing bars) from the two channels in the area of the crack to allow placement of the bottom tie plate. Some temporary lateral bracing may be required prior to completing the repair.
3. Bolt the bottom tie plate to the member.

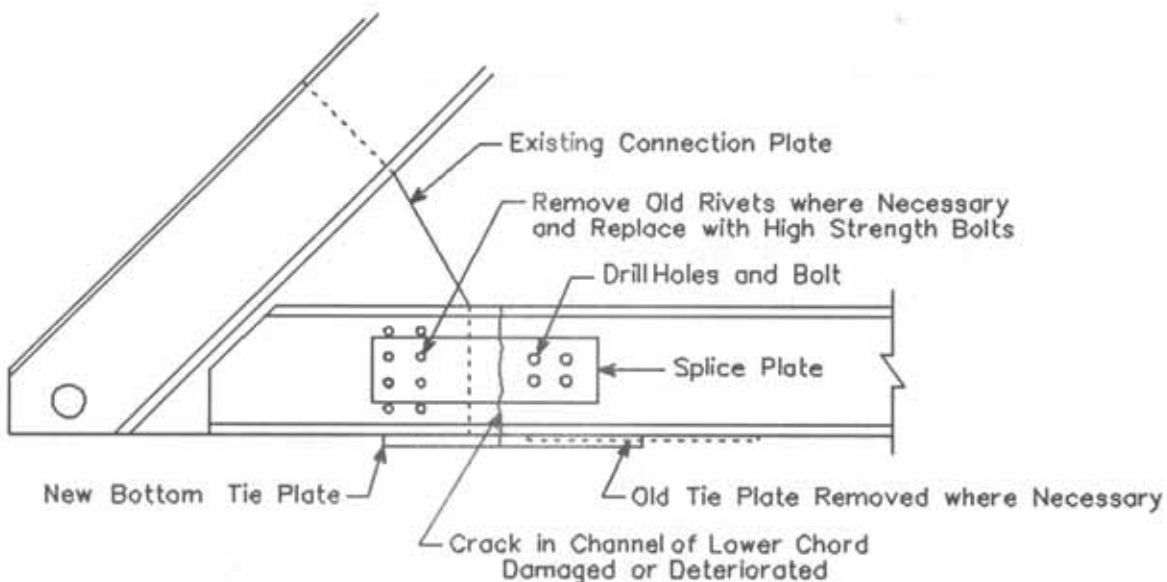

Exhibit XI.27 Typical Truss Repair Where Complete Removal is not Necessary

INCREASING THE VERTICAL CLEARANCE BY MODIFYING THE PORTAL BRACING

On many older through trusses, the vertical clearance is restrictive for today's larger trucks. The clearance is controlled by the portal brace connected to the top lateral strut, top chord, and/or end post at both ends of the span. The primary purpose of the portal brace is to support the truss against wind loads; however, it may have been designed also to provide support against buckling of the endpost. A modification of the portal bracing can be made to increase the vertical clearance. Exhibit XI.28 shows examples of possible modifications. An engineer shall design the

portal modification and the capacity of the end post should be checked since the unsupported length may have changed.

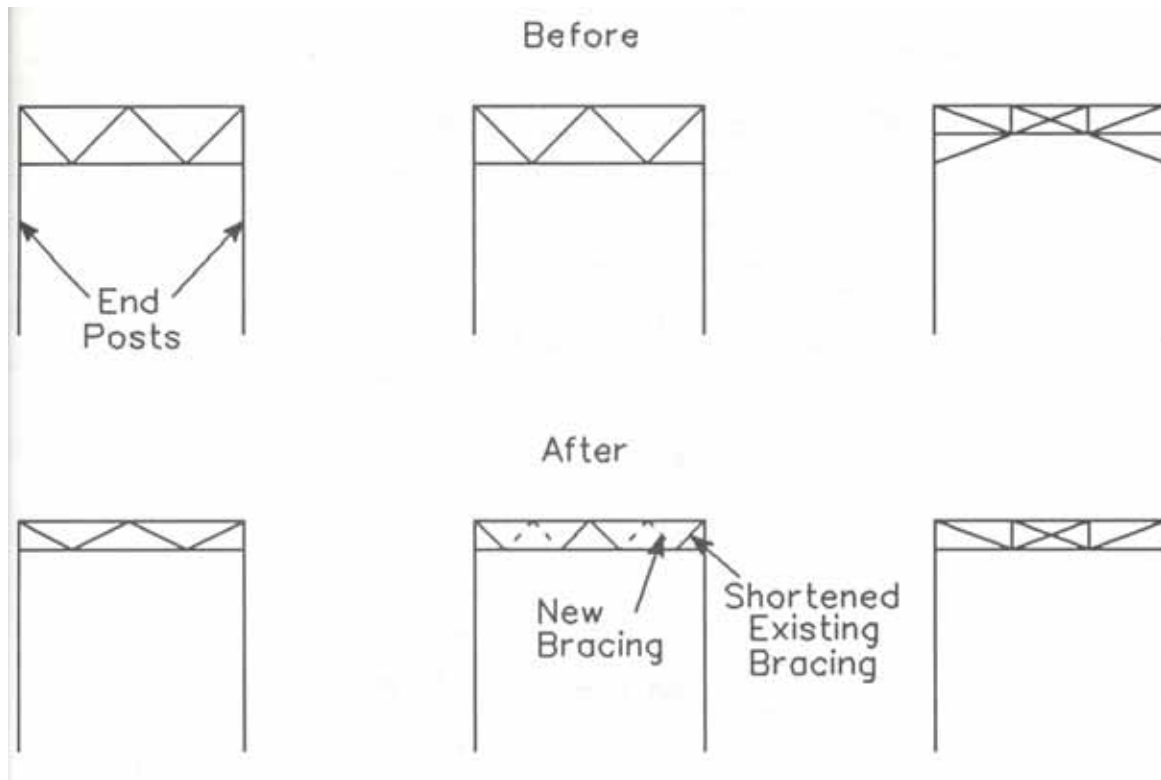

Exhibit XI.28 Examples of Portal Modifications

HEAT STRAIGHTENING OF DAMAGED TRUSS MEMBERS

MinnDOT repairs bent truss members using the heat straightening methodology described in the previous section on beam repair. The load is removed from the member to prevent stretching or buckling of the heated steel. This is accomplished by the installation of the yokes shown in Exhibit XI.29. The yokes are designed for either compression or tension members. The procedure is as follows:

1. Exclude traffic from the damaged side of the bridge.
2. Identify whether the damaged member carries tension or compression and obtain or fabricate the necessary yoke.
3. Tighten the clamps of the yoke down around the damaged portion of the member.
4. On tension members progressively tighten the threaded rods to remove the tension stress in the damaged member. On compression members, simultaneously apply jacking forces parallel to the member until the compression stress is relieved in the damaged member.
5. Using an oxyacetylene torch, apply heat to the member until a dull red color is reached. Do not exceed 550°C (1200°F). Apply the heat first to the bottom point of the "V". See Exhibits XI.23. Work slowly back and forth and progressively outwards.
6. During the cooling process of the heated area, shrinking occurs that tends to return the bent portion to its original shape.

7. Hammer peen the concave side of the bent member to help eliminate high residual stresses. Peening is done after the temperature of the metal has returned to a value less than 150°C (300°F).
8. This process can be repeated after the steel cools if the first attempt at straightening is inadequate.
9. Remove yoke and paint exposed steel.

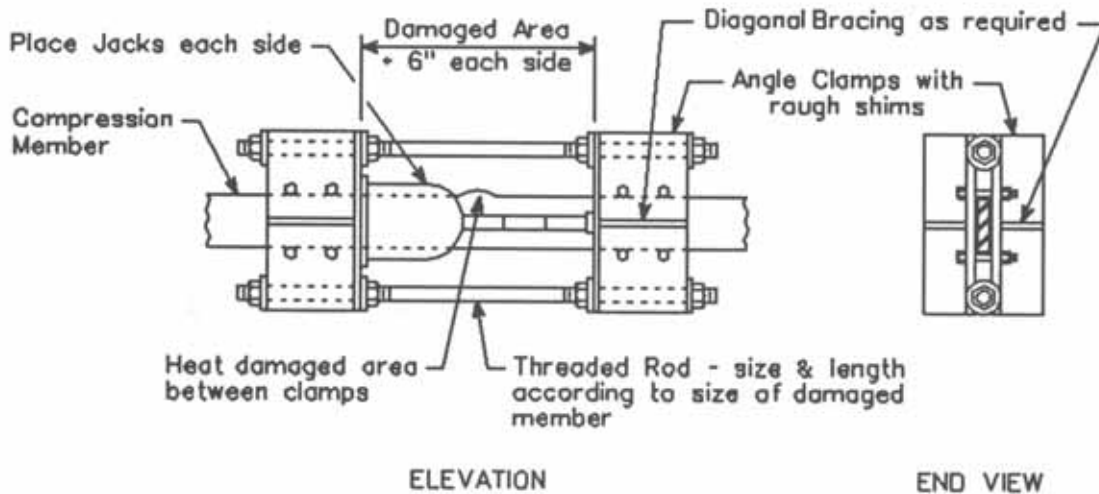
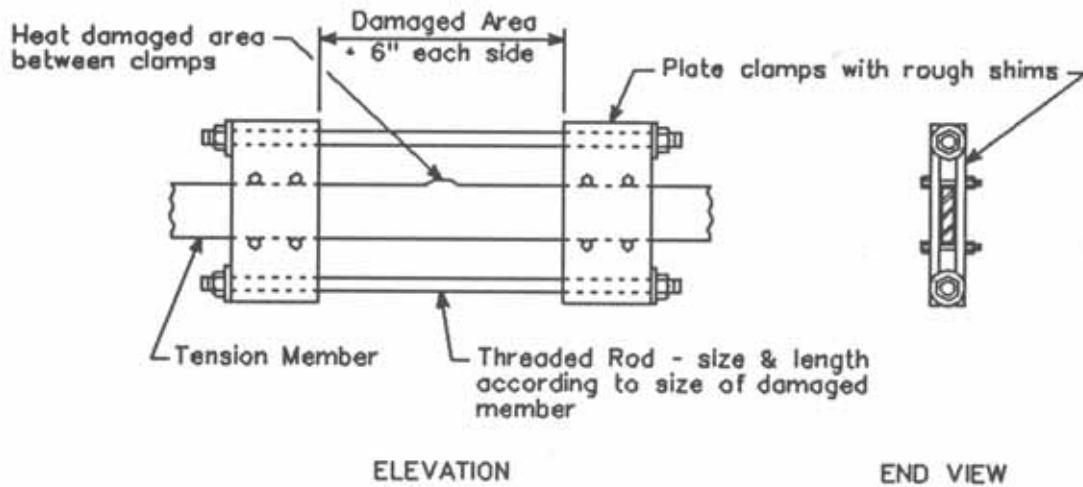

Exhibit XI.29 Yoke for Restoring Tension and Compression Members by Upsetting Heated Area

E. SPOT PAINTING

INTRODUCTION

Spot painting normally involves cleaning the surface, removing corrosion, and replacing the paint system on selected areas of the bridge. The replacement paint is selected for color match and compatibility with the existing paint. In the past, spot painting would often consist of removing corrosion and replacing with the system used originally on the bridge.

STATUS OF BRIDGE REPAINTING

The repainting of existing bridges has been drastically restricted and repainting costs have increased dramatically because of problems related to the toxicity of lead-based paints. According to NCHRP Report No.176, approximately 80 percent of the nation's steel bridges are coated with millions of pounds of lead paints.

There are several problems with paint removal: collection of the by-product of paint removal process including the blasting material, disposal of hazardous waste by-product, protection of the workers exposed to the cleaning process against exposure to lead and noise, and monitoring the lead level in the worker's blood.

Currently, most transportation agencies have stopped using maintenance crews to repaint bridges because of the problems noted above. Most repainting is now performed by contract. Contractors are enclosing the area to control air, water, and soil pollution during the cleaning and painting operation. The cleaning by-products are being collected and disposed of as hazardous materials. Workers are using special breathing equipment, changing clothes, showering at the site, and monitoring the lead in their blood.

Because of the rapidly escalating costs, the decision to repaint a bridge includes a comparison with the cost of not repainting and replacing the bridge when it becomes unsafe. Some bridge managers are deferring the decision to repaint bridges hoping that a less costly solution to the repainting problem will be found in the future. Some are experimenting with overcoat systems that paint over the corrosion to buy extra time. The best method of avoiding the paint removal problem is to repaint before the condition of the existing paint system deteriorates to the point that removal is necessary. Most state DOT's specify the paint system that is to be used. Preferences include zinc-rich systems, and vinyl systems.

PAINT SYSTEMS

Paint basically consists of two parts: 1) the pigment, which is made of fine solid particles to provide coloring and 2) the vehicle, which is the liquid portion to carry the pigment. The vehicle generally consists of a binder and thinners. The binders, with the embedded pigment, remain as the paint coat after the paint dries. The thinners reduce the viscosity of the binders and evaporate as the paint dries. Chemical reactions, in addition to drying, cause the binder in some paints to harden when the paint is exposed to air. Rapidly evaporating thinners are sometimes called dryers.

Red lead, titanium oxide, zinc chromate, and silicates are typical pigments. Some pigments perform a second function as in the case of zinc chromate, which adds corrosion resistance. Agencies have stopped using lead-based paints because of concerns and restrictions related to the environment and worker safety. Binders may be oils such as linseed oil or alkyds, latex, polyurethane, epoxy, and other chemicals. Thinners include turpentine, mineral spirits, acetone, and water within a long list of such substances.

New pigments, binders, and thinners are continually being developed to improve the ease of application, the quality and durability of the paint surface, and the protective qualities of the paint.

Painting protects bridges from corrosion. Corrosion is the destruction of metal by chemical or electrochemical reaction. Corrosion will shorten the life of a bridge unless the bridge is painted to protect it from this destructive process. Rusting of steel is the usual indicator of corrosion. The steel components of a bridge are susceptible to corrosion from atmospheric contaminants, water, salt spray, and deicing chemicals. Corrosion is often found under open joints, at the ends of girders, on the lower flanges of beams, on bearings, in crevices, between tightly fitted members, and in other locations that hold moisture and debris.

In addition to painting all exposed metal portions of a bridge, the practice of spot painting is important. It protects the bridge from corrosion and ultimately results in the saving of time and money. Spot painting consists of painting localized areas where the paint has been damaged or has failed, or corrosion has begun. Accomplishing spot painting as soon as defects are noted also provides the benefit of stopping or inhibiting corrosion before it progresses and requires significantly more time and money for a larger painting effort.

PREPARATION OF THE SURFACE

Preparation of the surface prior to painting is the most important element of the painting process. Although the major expense in painting may be in preparing the surface, it is worth the investment to ensure that the paint will adhere to the surface, provide a sound cover, and endure. Delay in spot painting will only increase the affected area and the effort required to prepare the surface. The preparation may progress from relatively simple wire brushing to the need for sandblasting if painting is delayed.

Surface preparation involves the removal of all corrosion, paint, or deposits that may interfere with the adhesion and covering ability of the paint to be applied. Paint should not be applied over loose, scaly, or flaking paint. Mill scale, rust, dirt, oil, and other foreign substances that prevent paint from adhering or covering must be removed before painting is done.

Effective methods of surface preparation are abrasive blasting; cleaning with powered metal brushes, scrapers, chisels, or hammers; or using similar hand tools. Water and dirt may be removed by air blast and wiping. Grease-like contaminants are most successfully removed by scraping, if the accumulation is large, and subsequently wiping or scrubbing with a petroleum-based solvent. Care must be exercised to ensure that oily substances are not simply diluted and

spread over a greater area. Vigorous wiping with a clean rag may be desirable to ensure residues will not interfere with paint adhesion.

Paint can be removed by a variety of methods. Each method differs in its cost of implementation, degree of containment required, quality of the prepared surface and the amount of debris generated.

METHODS OF SURFACE PREPARATION

Cleaning with Solvents

Heavy oil or grease accumulations on a surface require removal before abrasive blasting or other surface preparation since it interferes with, and may be spread further by, the surface preparation technique. Removal of lighter accumulations may be the entire surface preparation required in some areas.

Heavy oil or grease deposits and incorporated dirt may solidify with age so that the material is hard and thick enough to require scraping to remove the major portion. Preliminary scraping of the heaviest deposits usually saves time and solvent.

The solvents that may be used range from water in combination with special soaps through kerosene to some complex and hazardous chemicals such as di-isobutyl ketone (DIBK). A list of commonly used paint and cleaning solvents along with some of their properties and permissible concentrations is included in Exhibit XI.30. This exhibit should only be used as a guide; specific information for any solvent shall be obtained from the manufacturer of the solvent.

Properties of solvents that are relevant to their use in surface preparation because of health and fire considerations are as follows:

Relative Evaporation Time -The relative time required for the solvent to completely evaporate, based on a value of 1.0 for ethyl ether. The higher the number, the longer the time required for evaporation.

Flash Point -The temperature at which the solvent releases sufficient vapor to ignite in the presence of a flame. The higher the flash point, the safer the solvent.

Explosive Limits (Flammable Limits) – Expressed as a percentage of solvent vapor in a total volume of a vapor plus air. Minimum concentrations below this percentage will not ignite. Maximum concentrations above this percentage will not ignite. Concentrations between the minimum and maximum range will ignite or explode.

Maximum Allowable Concentration (M.A.C.) – The concentration of solvent vapor in the air that can be tolerated throughout an 8-hour day, expressed in parts per million (PPM). The higher the value the safer the solvent. Common solvents such as carbon tetrachloride and benzol are very toxic.

	Relative Evap. Time	Flash Point (°F)	Explosive (percent by Volume)		Max. All Concentration (PPM)
			(Min)	(Max)	
Acetone	4	10	2.6	12.8	1,000
Amyl Acetate	50	100	1.1	7.5	200
Amyl Alcohol	100	115	1.2	10.0	100
Benzene (Benzol)	8	10	1.4	7.1	25
Butyl Acetate	30	90	1.7	7.6	200
Butyl Alcohol (Butanol)	70	105	1.4	11.2	100
Carbon Tetrachloride	8	---Not Flammable---			100
Diacetone Alcohol	200	145	1.8	6.9	25
Di-isobutyl Ketone (DIBK)	150	140	0.8	6.2	50
Ethyl Acetate	8	40	2.5	9.0	400
Ethyl (Grain) Alcohol (Ethanol)	20	60	4.3	19.0	1,000
Ethylene Glycol Monoethyl Ether (Cellosolve)	100	110	2.6	15.7	200

	Relative Evap. Time	Flash Point (°F)	Explosive (percent by Volume)		Max. All Concentration (PPM)
			(Min)	(Max)	
Ethylene Glycol Monoethyl Ether Acetate (Cellosolve Acetate)	32	130	1.7	No data	100
Hi-Flash Naphtha (Aromatic)	105	105	1.0	7.0	200
Isopropyl Acetate	10	50	1.8	7.8	200
Isopropyl Alcohol (Isopropanol)	25	65	2.5	12.0	400
Methyl (Wood) Alcohol (Methanol)	10	55	5.5	36.5	200
Methylene Chloride	4	--Not Flammable--			500
Methyl Ethyl Ketone (MEK)	8	30	1.8	10.0	200
Methyl Isobutyl Ketone (MIBK)	20	65	1.4	7.5	100
Mineral Spirits (Petroleum Thinner)	150	105	0.8	7.0	500
Refined Kerosene	800	150	0.7	5.0	500
Toluene (Toluol)	15	45	1.3	7.0	200
Turpentine	100	105	0.8	No data	100
VM & P Naphtha (Benzine)	20	50	1.1	5.9	500
Water	100	--Not Flammable--			--
Xylene	35	85	1.0	6.0	200

Exhibit XI.30 Paint and Cleaning Solvents

Paint should not be applied over solvents, so evaporation times should be considered when selecting the solvent. Evaporation times for some commonly used solvents are given in Exhibit XI.31.

SOLVENT	EVAPORATION TIME (MIN.)
Naphthas, Aliphatic	
Kerosene 325	
Odorless Mineral Spirits	60
Mineral Spirits	35
Stoddard Solvent (L)	33
Stoddard Solvent (T)	35
VM & P Naphtha	04
High Flash Naphtha	04
Lacquer Diluent	02
Naphthas, Aromatic	
SC Solvent #150	98
SC Solvent #100	21
SC Solvent #2 14	
Xylol or Xylene	11
Toluol or Toluene	03
Benzol or Benzene	01
Terpenes	
Pine Oil	465
Dipentene	33
Gum Turpentine	16
S. D. Wood Turpentine	14

Exhibit XI.31 Evaporation Time for Solvents

Safety Precautions

Safety is the first consideration in using solvents because of health and fire hazards. The following minimum safety precautions apply to the use of any solvent:

- Wear goggles, protective clothing, rubber gloves, and barrier cream (petroleum jelly).
- Do not breathe the fumes. (Proper ventilation is always required).
- Do not use benzene and carbon tetrachloride since they are poisonous.
- Do not use gasoline or solvents with low flash points since they might catch fire or explode.
- Do not smoke or use solvents near fire, flame or electrical connections.

- In case of skin contact, clean thoroughly with soap and water.
- In case of eye contact, rinse with water immediately and contact a physician.

When using solvents in surface preparation, the first step is to remove dry material with a stiff bristle or wire brush and scrape off any thick deposits. The oil or grease is then removed by scrubbing or wiping the surface with rags wetted with the solvent. Soaking with a solvent-wetted rag and scrubbing with a brush are effective on heavy or partially solidified deposits. The final wiping should be done using solvent and clean rags to ensure complete removal of the oil or grease.

Hand Cleaning

This method of cleaning is laborious and is used to remove old paint or corrosion from only small areas. Solvent should precede hand cleaning when there is oil or grease on the surface. The advantages of hand cleaning are that it greatly reduces the amount of material for disposal and it does not require large or expensive equipment. Hand cleaning is used to prepare areas where the paint is in fairly good condition with only a few bad spots. Also to clean around rivets, welds, joints, or in corners and "blind" spots that other methods did not reach, or on larger areas where traffic does not permit the use of other methods.

Hand cleaning operations easily lead to injuries, particularly to the eyes from flying debris and to the hands from sharp edges and slips. Goggles should be worn at all times, and heavy fabric or leather gloves are a must. Tools should be handled carefully to avoid slips and injury.

This method generates a minimum of dust. Workers must still use protection from airborne debris. The debris is limited to paint, rust, and mill scale being removed and not to the abrasive used as in the case of blast cleaning. Hanging a few tarps around the work area may satisfy containment requirements. Handtools have been equipped with vacuum hoses to collect airborne dust particles. Handtools for cleaning involve the use of:

- Handwire brushes
- Chipping hammers
- Scrapers
- Sandpaper
- Chisels
- Dust brushes
- Sanding blocks
- Putty knife
- Brooms

Rust chips or scale should be removed with chipping hammers, chisels, or scrapers; the surface should then be wire brushed. Chipping hammers or scrapers can be used to remove tightly clinging pieces of paint. Light rust can be removed by vigorous wire brushing. The surface should be cleaned of dust, rust, and paint particles with a dust brush or broom and wiped down

with a clean rag before paint is applied. Compressed air may be used for the final cleaning. Handtool cleaning is covered by the Steel Structures Painting Council (SSPC) SP2 Handtool Cleaning.

Power Tool Cleaning

Power tools include:

- Impact tools
- Brushing tools
- Rotary scarifiers
- Grinding tools
- Needle guns

Power tool cleaning removes rust, loose paint, and mill scale. As with handtool cleaning productivity is low and the compatibility of the paint system must be gauged. The dust generated by power tools is generally greater than that created by handtool cleaning, but still considerably less than that generated by grit-blast cleaning. Containment again consists simply of tarps placed around the work area.

Power tool cleaning is covered under SSPC-SP3 and SSPC-SP11. SP3 covers power tool cleaning which removes loose material. SP11 covers power tool cleaning to bare metal.

Power Tool Cleaning with Vacuum Attachments

Power tools can be equipped with vacuum attachments to collect the dust and debris. The degree of dust generated is minimal but some dust will escape in areas of difficult configuration or where complete seals are difficult to attain. The shrouding can also restrict accessibility in hard-to-reach areas. Debris consists of only the products removed from the steel surface. Productivity is lower than power tools without the vacuum attachments

Chemical Stripping

Chemicals can be applied to the steel surface to soften the paint for scraping or water washing removal. Chemicals such as sodium hydroxide or methylene chloride are applied to the surface and are allowed to remain in contact with the surface for a few hours, or over night.

The stripper and wash water must be collected for proper disposal. Dust tight containment is not necessary. In this method, the containment must be capable of capturing the stripper debris and wash water. The stripper is hazardous due to its entrained lead particles and in some cases due to its pH value. Some strippers are hazardous wastes in themselves. The volume of waste may be increased if the rinse water tests hazardous and cannot be filtered from the debris.

Strippers will not remove rust or mill scale. Blast cleaning may be utilized after the strippers have been used to provide a prepared surface for painting. If follow up abrasive blast cleaning is

utilized, some containment may be required to contain dust even though the lead based paint has been removed.

Productivity with strippers can be slow especially if repeated applications are necessary. Follow-up mechanical surface preparation is some times required.

OVERCOATING

Overcoating is an alternative to cleaning lead-based paints, containment, and repainting steel. The overcoating system is a process of applying a surface-tolerant coating to a minimally prepared surface and existing layer of lead containing coating. The surface is prepared typically using power water washing, which removes dirt, chalk, and chlorides. In isolated areas a combination of hand and power cleaning may be utilized. Overcoating eliminates open air grit blasting. Prior to overcoating, steel surfaces are spot painted with a one-component moisture-cured polyurethane aluminum primer. A polyurethane intermediate coat that meets volatile organic compound (VOC) requirements can then be applied to the entire bridge surface. The repainting is completed with a VOC-compliant light-stable polyurethane top coat.

Painting costs can be reduced from 30 to 75 percent using the overcoat method. Overcoating is applicable on bridges for a maximum of 25 to 30 percent of its surface if corroded or if its paint breaks down. Important to the success of the overcoating painting method are the special surface-wetting, edge-sealing, and curing capabilities of the moisture-curing polyurethane spot primer. The low-viscosity primer has the ability to penetrate and wet out the old paint and tightly adhering rust. In addition, the wetting ability allows the primer to penetrate under old paint and spot clean the areas. To cure, the primer scavenges moisture from the rust, the atmosphere and the existing paint.

Several important factors help determine if a structure is a candidate for overcoating. The following factors must be evaluated:

- The percentage of rusted areas
- The degree of rusting
- Steel condition
- Adhesion of the coating
- Adhesion between layers of the coating
- Paint type of the undercoating (it may be difficult to develop proper adhesion between leafing, pigmented paints and the new coating)
- Reparability of the coating
- Compatibility of the existing coating systems (test patch areas may be used)

SPOT PAINTING GUIDELINES

Spot painting consists of painting damaged, repaired, or corroded members of a bridge where less than 35 percent of the paint on the structure has deteriorated. . Generally, if more than 35 percent of the bridge requires painting it is advisable to paint the whole structure since the remaining portion will need painting soon.

The first consideration in selecting the type of paint to be used is whether the new paint will be compatible with the old. Paint formulas are constantly being changed and many of the new paints will not adhere, cover, or endure if applied over older types. The general rule is to spot paint with the type of paint already on the structure. If this is not possible, paint manufacturer's technical data should be utilized to select a compatible paint. Spot painting should be done with a matching color to maintain a neat appearing structure.

The spot painting procedure differs from painting the entire structure in the following respects:

- Only the part of a member that has corroded is cleaned to bare metal
- Since only a part of a member may have been cleaned to bare metal, only that part needs prime coat.
- The final coat is restricted to the areas to receive spot painting.

WEATHER CONDITIONS

Weather plays a major role in determining the quality of a paint job, and weather forecasts should be used to schedule painting operations. Painting should be done as soon as possible after, and on the same day as, the surface preparation is completed. Surface preparation in difficult or protected areas, such as on bearings or beam ends, may be started on unsuitable painting days and completed when a good painting day occurs. The best painting quality results from applying the paint in warm, dry weather with little or no wind. Spray painting should not be performed in winds over about 7 meters per second (15 mph) because the spray will be carried to deposit on vehicles and the surrounding area.

Paint should not be applied at temperatures below 4°C (40°F) or when the temperature may drop below 0°C (32°F) before the paint dries. Curing reactions and solvent evaporation are slowed or stopped by low temperatures so that a longer drying time between paint coats is required. Water-based products may freeze. Proper coating thickness is more difficult to achieve at low temperatures because the paint thickens. Zinc primers are an exception since they may be applied at temperatures below 4°C (40°F) when the humidity is low.

Painting in hot weather thins the paint so the coating may be too thin, makes it more likely to run and sag, and may lead to blistering from trapped solvents that are not able to evaporate through the surface film. Adding too much thinner may compound the problems. Paint should not be applied to surfaces with temperatures over 50°C (125°F) unless the paint is specially formulated for high temperatures. Use of a thermometer to check surface temperatures is a wise practice. Spray painting at high temperatures increases overspray and results in excess trapped air and solvent bubbles on the paint surface. Organic zinc paints develop film cracks at high temperatures. The life of mixed component paints in paint pots is reduced by high temperature.

Paint should not be applied when the relative humidity is greater than 85 percent, there is mist or fog, or the surface is damp from dew or frost. Even in warm weather, high humidity will cause

the paint to dry more slowly; more time to dry will be required between coats. Moisture prevents the paint from bonding to a surface so any indication that the surface is becoming moist from condensation is cause to stop painting. Very low humidity can cause film cracks from rapid drying of water-based paints and may result in inadequate curing of other solvent-based paints.

Humidity can be determined with the aid of a Sling Psychrometer, which employs a wet bulb and a dry bulb thermometer to measure the moisture in the air. A wet film test consisting of wetting a cloth enough to leave a film of water when wiped on a surface may also be used. If the film evaporates within 15 minutes, the humidity is low enough to permit painting.

Wind, particularly over 7 meters per second (15 mph), may blow dirt onto fresh paint surfaces and leads to several spray painting problems. The spray can be blown off target, the solvent evaporates too quickly and results in a dry spray that does not stick at the edge of the pattern, and lap marks become more obvious.

THINNERS

Thinners reduce the viscosity or thickness of paint and do not impair the vehicle. Too much thinner results in a coating that is not thick enough to protect properly. Thinners should be used only when specified or necessary. The paint manufacturer's recommendations should be followed on the kind and amount to use. When it is necessary to substitute, the thinner should be compatible with the paint. A small quantity of paint and thinner should be mixed. The thinned paint or a surface painted with it should be checked for separation or other irregularities. Paint should be mixed to a uniform consistency, the thinner measured and added, and the paint remixed.

In cold weather it may be necessary to add more thinner. If extra thinner is added, enough paint should be applied to get the correct coating thickness. If enough paint is not applied on the first coat, extra coats must be added to obtain the proper thickness.

CARE AND STORAGE OF PAINT

The proper care and storage of paint is essential for maintaining the quality of the material and for safety reasons since many paints are toxic or constitute a fire hazard. A reasonable inventory of paints promotes efficiency.

Paint should be stored at temperatures between 18°C (65°F) to 30°C (85°F) in a dry, well ventilated area where it will not be exposed to excessive heat or cold, explosive fumes, sparks, flame, or direct sunlight. Paint and solvents should be stored in a location apart from other combustibles, preferably in a separate building, because of the fire hazards. Temperatures over 38°C (100°F) can ruin paint by causing a reaction of the components or causing the container to burst open. Too low temperature, particularly freezing, can also ruin paint. Paint stored where the temperature drops below 18°C (65°F) must be conditioned by keeping it at 18°C to 29°C (65°F to 85°F) for 24 hours before using it.

The following paint storage practices should be observed:

- Store paint neatly; keep aisles and walkways clear for safety.
- Ensure labels are intact and readable. Relabel containers accurately.
- Containers should remain unopened until required for use.
- Previously opened containers should be used first.
- The oldest paint should be used first.
- If a skin of dried paint has formed on the surface of the paint in a previously opened container, cut the skin out, throw it away, and thoroughly mix the remaining paint.
- Pour partially used containers of paint of the same type and color into one container to reduce the amount of air space that causes a skin to form.
- Ensure that partially used containers are sealed tightly to prevent contamination and drying of the paint.
- Recheck container lids periodically to ensure the lids are tightly sealed.
- Invert containers in storage each month or two to prevent pigments from settling and caking on the bottom of the container.
- Do not try to salvage improperly stored paint. Return it to the stockroom for disposal and notify the supervisor of the condition and identification of the paint.

INSPECTION OF PAINTING

Painting is not completed until the coating has been inspected to locate any deficiencies and they have been corrected. The inspection techniques are designed to reveal defects, such as porosity, pinholes, blisters, unpainted areas, and the thickness of the coating.

A flash magnifier, a flashlight-equipped with magnifying glass, can be used to detect and examine surface irregularities. A holiday detector, an electric current measuring device, can be used to locate thin paint and pinholes.

The thickness of the paint coat can be measured when wet with a wet mil gauge and when dry with a dry mil gauge. The wet mil gauge simply consists of a set of prongs varying in length by 0.025 mm (.001 inch) that is pushed against the painted surface, and the prongs with or without paint indicate the thickness of the coat. The paint thickness should be checked frequently during the painting operation to ensure adequate cover. A dry mil gauge generally measures the paint thickness in thousandths of an inch through the use of a magnet, although one type uses a destructive means of making calibrated scratches in the paint and measuring the width to

determine the paint thickness. It is important to check the thickness of each coat after it has dried before applying the next coat to ensure proper cover.

Before applying successive coats of paint, it is necessary to touch up damaged areas, repaint areas with insufficient mil thickness, and repair and repaint all unsatisfactory areas.

DEFECTS IN PAINT

The description, cause and repair of common painting defects are:

Alligatoring- A mesh of paint cracks that resembles alligator hide, with the coating pulling away from the surface and causing a rough finish. It is usually caused by not allowing sufficient drying of the paint before recoating, extreme temperature changes, and incompatibility between coats of paints as when a vinyl paint is applied over an alkyd paint. The remedy is to remove the finish down through the damaged paint film and refinish the area. A solvent recommended by the paint manufacturer should be used. Paint should be mixed thoroughly before applying. Sufficient time for drying should be allowed between coats of paint. Compatible paints should be used.

Blistering- There are many causes of blistering. The cause may be that the topcoat did not adhere to the primer, the paint was applied over oil or moisture, too much paint was applied at one time, steam cleaning caused disbonding, fingerprints were on the metal, or air was trapped under a very thick coating of paint. Correction requires sanding with #400 paper, or a ball of screen wire, to remove blisters and refinishing. Products should be thinned properly. Sufficient drying time should be allowed between coats. There should be no water in the airlines when spray painting.

Lifting- Incompatible coatings may not wrinkle or alligator. Instead, the incompatible coating may cause the coating beneath it to lose its adhesion and result in both coats peeling from the surface. This is caused by the solvent in the topcoat acting as a paint remover on the coating beneath. This is likely to occur when paints containing strong solvent such as xylene are applied over soft oil-based paints. Lifting may also occur if an undercoat is not allowed to dry properly before applying the next coat. Painting over dirty, oily, or greasy surfaces may also cause lifting. Lifting should be repaired by removing the finish down through the damaged paint film and refinishing the area. A solvent recommended by the paint manufacturer should be used. The paint should be mixed thoroughly before applying. Sufficient drying time should be allowed between coats of paint. Compatible paints should be used.

Pinholing (Bubbling, Solvent Pops)- These defects are quite common in coatings. Pinholing is often the result of water contamination in the airline of the sprayer, or a solvent imbalance (a solvent that is drying too quickly). The coating does not have enough time to flow out before it dries and little holes are left in the coating. Trapped solvents, settling of pigments, and insufficient atomization of the paint may also cause pinholing. Should pinholing occur, it may be necessary to consult a materials laboratory so that the cause can be determined and eliminated. One successful remedy is to use a considerably thinned tie coat or primer or to thin the top coat 25 percent to 50 percent. This will seal the porous surface of a zinc-rich primer. When the use of a tie coat is not acceptable, a mist coating of the topcoat paint should be applied over the surface.

This should be followed by a full topcoat. In extremely severe cases of pinholing, it may be necessary to sand to a smooth surface and refinish. Prevention of pinholing involves the prevention of water entry to the sprayer airlines, not applying paint too heavily, and proper evaporation of the solvents. Recommended thinners and sufficient air pressure for proper atomization should be used.

Runs- When this defect occurs, the wet paint film runs in rivulets. It is caused by over-thinning, extra slow evaporating thinners, improperly cleaned surfaces, or too cold surfaces. Holding the spray gun too close to the surface and depositing too much paint on the surface is also a cause of runs. Repair should be made by sanding and washing off the surface and refinishing. The surface should be cleaned thoroughly. Paint should not be applied over an old surface. The paint should be thinned as recommended using specified solvents.

Sags- Sags consist of heavy thicknesses of paint that have slipped and formed curtains on the surface. This is caused by insufficient thinner, insufficient drying time between coats, low air pressure causing insufficient atomization, holding the gun too close to the work, or a gun out of adjustment. Repair should be made by sanding and washing off the surface and refinishing. The paint viscosity should be reduced as recommended by using a proper thinning solvent. The air pressure and the gun for correct atomization should be adjusted, and the gun should be kept at the correct distance from the work.

Improper Repair- Holes and cracks that are not filled and repaired properly will allow moisture to get behind the coating and cause blistering, flaking, and peeling.

Insufficient Coating Application- If too little paint is applied or the paint has been thinned too much, chalking and erosion will deteriorate the film soon. Care must be taken to see that there is sufficient paint over the top of the surface roughness to prevent corrosion starting on the peaks.

Incompatible Paints and Thinners- The importance of using compatible paints and thinners has been stressed repeatedly. Exhibit XI.32 provides a general guide to selecting compatible products to avoid the problems that have been described. The primer to be used should be found at the top and the desired topcoat on the left side of the chart. If there is a "G" at the intersection of the primer and topcoat, they are compatible. If the intersection square has a "M", the compatibility is marginal. If the square has a "NR", the selected topcoat is not compatible with the primer. It should be remembered that inorganics will not stick over organics.

***Indicates that "BLEED-THRU" may be severe problem**

PAINTS AND COATINGS COMPATIBILITY GUIDE

Note: LONG MS-85 is basic Lead
Lead Silico Chromate

KEY: G - Good, Recommended
M - Marginal
NR - Poor, Not Recommended

TOPCOAT	PRIMER OR PREVIOUS COATING																
		Alkyd & LDN MS-85	Bituminen	Chlorinated Rubber	Epoxy-amine	Epoxy-Coal Tar	Epoxy Ester	Epoxy-Polyamide	Latex	Oil Base & LDN MS-85	Phenolic (Modified)	Polyester	Silicone	Silicone-Alkyd	Urethane(Mod.) Roughen Surf Fat	Vinyl	Zinc-Inorganic
Acrylic	G	M	M*	G	G	G	M	G	G	G	G	G	G	M	G	G	G
Alkyd & LONG MS-85	M	G	G	G	G	G*	G	G	M	G	G	G	G	G	G	G	NR
Bituminen	G	G	G	G	G	G	G	G	G	G	G	G	M	M	G	G	G
Chlorinated Rubber	M	G	M*	G	G	G*	G	G	G	G	G	G	G	G	G	G	G
Epoxy-Amine	NR	NR	NR	NR	G	G*	NR	G	NR	NR	G	G	NR	NR	G	NR	G
Epoxy-Coal Tar	NR	NR	M	NR	G	G	M	G	NR	NR	G	G	NR	NR	G	NR	G
Epoxy Ester	G	M	M*	G	G	G*	G	G	G	NR	G	G	M	M	G	G	M
Epoxy Pelyamide	NR	NR	NR	NR	G	G*	NR	G	NR	NR	G	G	NR	NR	G	NR	G
Latex	M	M	M	M	M	M*	M	M	G	M	G	G	M	M	M	M	G
Oil-Base	M	G	G*	G	G	G*	G	G	M	G	G	G	G	G	G	G	NR
Phenelic (Modified)	NR	NR	NR	NR	M	M*	NR	M	NR	NR	G	G	NR	NR	M	NR	G
Polyester	NR	NR	NR	NR	M	M*	NR	M	NR	NR	M	G	NR	NR	M	NR	NR
Silicone	G	M	M*	G	G	G*	G	G	M	M	G	G	G	M	G	G	G
Silicone-Alkyd	M	G	G*	G	G	G*	G	G	M	G	G	G	G	G	G	G	NR
Urethane (Modified)	NR	M	M*	M	M	M*	M	M	M	M	G	G	M	M	G	M	G
Vinyl	M	NR	M*	G	G	G*	M	G	M	NR	G	G	M	M	G	G	G

Exhibit XI.32 Recommended Primer/Topcoat System

WEATHERING STEEL

Under certain conditions weathering steel requires maintenance coatings. The corrosion of weathering steel presents certain unique surface preparation problems. The advantage of weathering steel is that the rust that forms on its surface is stabilized by the effect of the alloying elements contained in the steel and the corrosion of the metal is thereafter inhibited by that rust layer. The rust layer, however, does not properly form in salt water spray or fog, or salt laden fog environments. Weathering steel does not perform properly in the vicinity of bridge deck joints due to deicing salts.

The uniqueness of the corrosion of weathering steel causes a significant problem when surface preparation is considered:

- The pits that develop in weathering steel are very deep relative to the diameter. This makes it difficult to properly clean the bottom of pits.
- The removal of chlorides from the bottom of pits is difficult.
- The green mold phenomenon is a discoloration that appears shortly after blast cleaning.
- Repeated blast cleaning is often required.

PREVENTIVE MAINTENANCE

Maintenance crews should understand the importance of PM on weathering steel to prevent deterioration and to minimize maintenance requirements. Corrosive conditions, which require PM, are listed below:

1. Exposure of beam ends to leaking deck joints, especially in presence of deicing salts.
2. Exposure of exterior beams to rain due to a short deck overhang, e.g., overhang length less than girder height.
3. Exposure of exterior beam to water streaks running over the edge of the deck.
4. Crevices and pockets that trap moisture.
5. Exposure of beams to air borne salt.

To prevent the weathering steel from corrosion, steel members should be painted. For example, for protection against deck joint water leaks, steel members should be painted a 2-m (6.5-ft) length on both sides of the joints. Other PM measures include:

1. Ensure free and rapid water runoff.
2. Collect all water on deck and discharge it below the bottom of steel elevation.
3. Maximize drainage pipe slope.
4. Prevent splashing.
5. Maintain drainage system to avoid clogging.